

Car Park Ventilation



Mechanically vented car parks are designed to operate with either traditional ducted or modern impulse ventilation systems. Our car park fans operate on well-proven tunnel ventilation principles, producing a high velocity jet that, as it diffuses, imparts thrust to the surrounding air through mixing and entrainment.

We manufacture a range of fans including axial and centrifugal variants for both general ventilation and emergency situations in car park applications.

Our JetVent range includes induction and impulse ventilation models specifically developed to operate as both general ventilation and for once-only, emergency extract mode at temperatures of up to 400°C.

The product design eliminates the requirement for ducted systems, making efficient use of the limited space of enclosed car parks, in addition to reducing power consumption and the associated running costs.

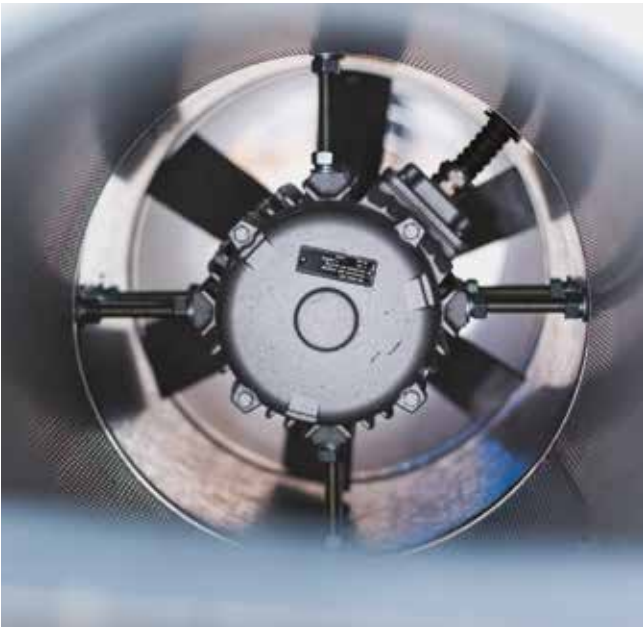



PART OF ELTA GROUP

Across all of our people, in all of our businesses, on all continents on which we operate, Elta Group has one purpose: To enhance life through air.

For 20 years we have been a proudly independent, family-owned group, but our foundations were laid over 45 years ago. Our foundations were built on an entrepreneurial spirit and a clear vision of meeting market needs and improving air quality. These have seen us become a leader in high-integrity solutions that move, filter, treat and distribute air, from agriculture to building services to applied technology. We're never standing still, always living and breathing our cause, and looking to the horizon.

eltagroup.com

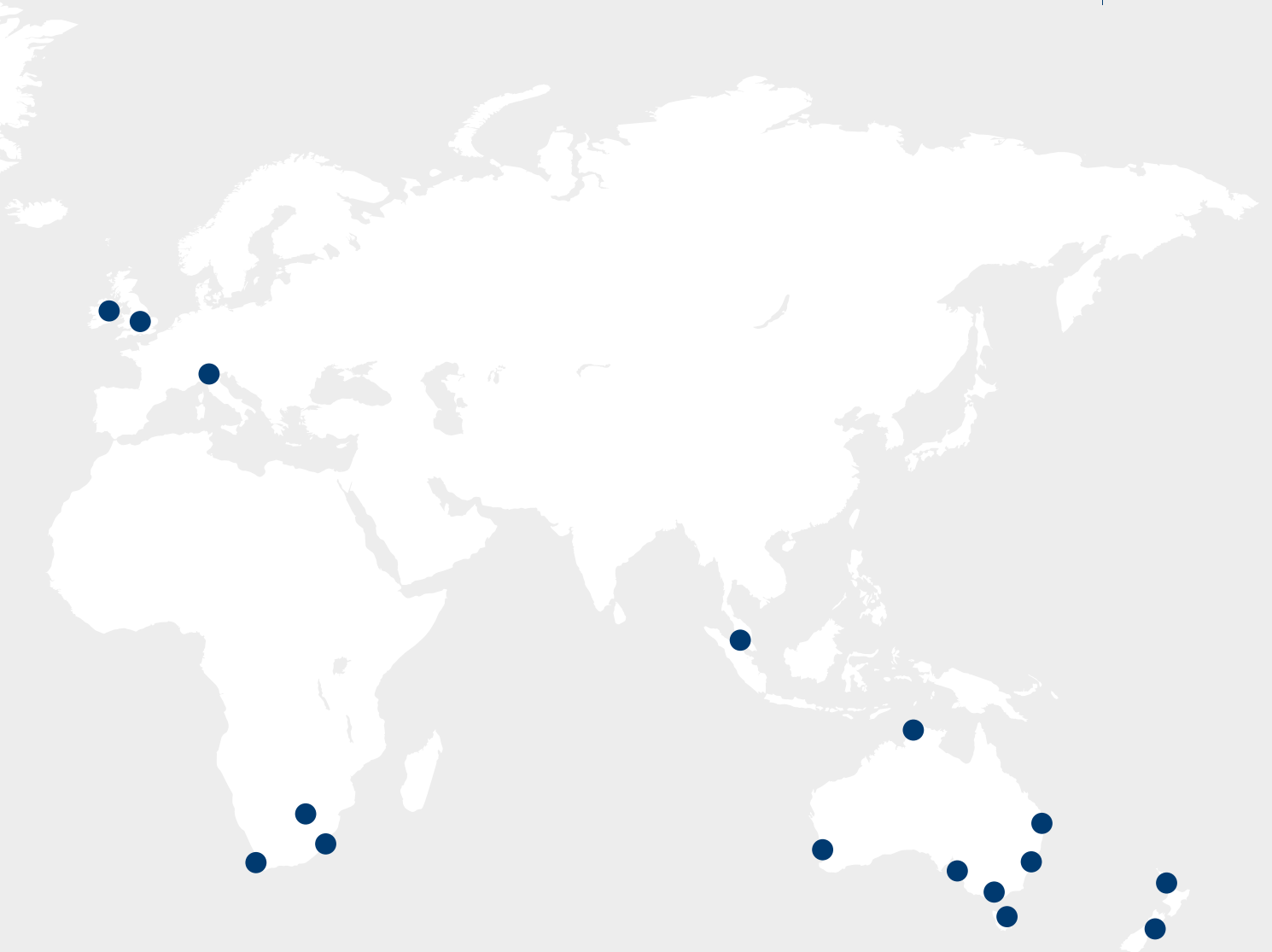

Europe
Africa
Asia
Australasia
REGIONS

Building Services
Applied Technology
Agriculture
International
MARKETS

Fans
Air Handling
Heat Recovery
Filtration
Natural Ventilation
Acoustics
Air Distribution
Controls
Heating
Cooling
Welfare
Lighting
PRODUCTS





Impulse Ventilation

The impulse ventilation system is based on a number of small, strategically located high velocity fans in place of the distribution ductwork traditionally used in car parks.

Impulse fans operate on well-proven tunnel ventilation principles, producing a high velocity jet which thrusts against the air in front of the fan imparting momentum to all the surrounding air through entrainment as it diffuses. The volume of entrained air is significantly greater than that passing through the fan. The impulse fans are carefully positioned to direct the airflow towards the main extract fan intake points.

JetVent Axial Impulse Fans

JetVent Axial Impulse fans have been specifically designed to provide a high velocity airflow to help overcome problems caused by obstructive structural beams and low overall ceiling heights found in car parks. The innovative design of JetVent Axial Impulse fans provides major benefits in terms of reduced installation and running costs as well as effective smoke control.

Technical excellence and innovation in design are the cornerstones of an Elta Fans product - JetVent is no exception to this approach. The harmony of our engineering excellence and technical sophistication combine to provide a first class product which meets demanding smoke, as well as general fume, applications.

With tomorrow's technology at our finger tips, utilising market leading software, Elta Fans can pinpoint, analyse and make design changes and improvements without the expense of conventional prototyping, working with our customers to meet their specific needs.

Conventional & Impulse Ventilation

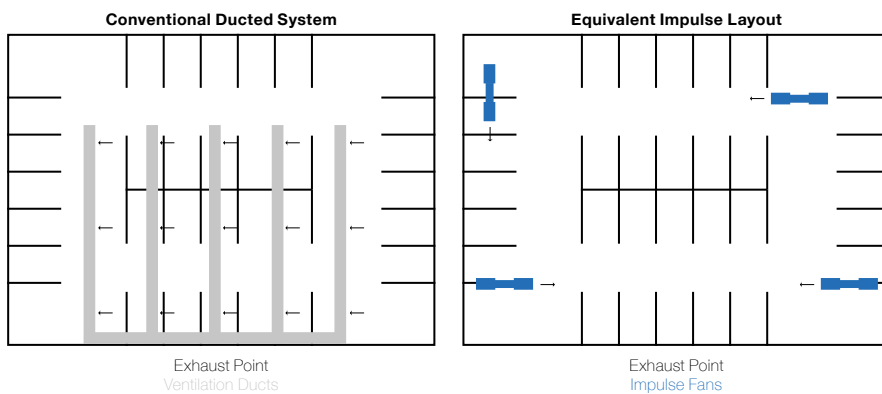

The distribution ducting used in traditional systems is replaced by a number of small JetVent impulse fans to direct the airflow across the designated area. Without the distribution duct resistance, smaller exhaust and supply fans and / or motors can be used.

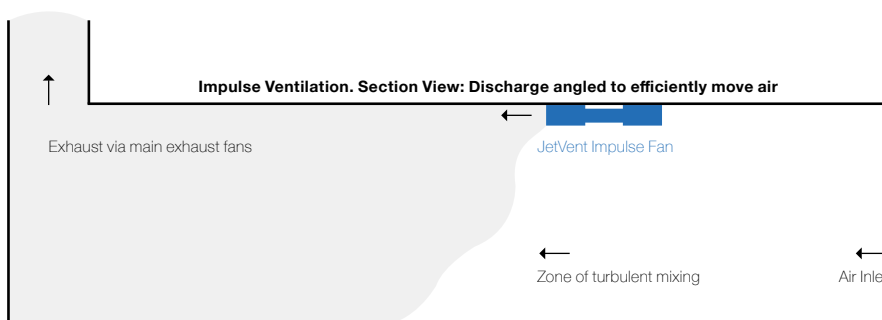

Features & Benefits

The JetVent Axial Impulse fan range is available with either unidirectional or truly reversible airflow. JetVent can run in either normal extract mode or once only smoke operation at up to 400°C for 2 hours which means cost savings as a single fan provides both general and smoke extract requirements.

Better Security

The elimination or reduction in ductwork means a safer, lighter environment with better security due to the increased visibility.

No Ductwork

By adding momentum to the air, JetVent thrusts air towards the desired extract points to ensure stagnant fumes and smoke are cleared effectively and efficiently. This principle eliminates the requirement for ductwork within a car park, as the JetVent effectively transfers the polluted air, allowing for better use of limited space in underground facilities.

Low Maintenance

With no ductwork, maintenance costs are reduced as there is no ducting to become blocked, damaged or subject to leakage.

Cost Effective

JetVent provides the scope for reduced installation and overall construction build costs compared with traditional ducted systems. The high efficiency impellers make this a very economical method of moving high volumes of air.

Design Appeal

The integral bell mouth inlet has a streamlined appearance for improved performance and sound.

Robust Design

JetVent axial fans are of a robust, heavy duty construction for added strength and durability. Fan casings are heavy gauge, sheet steel, roll formed and welded and hot dipped galvanised after fabrication to BS EN ISO 1461.



Performance & Dimensional Data

Flanged Units

JetVent Unidirectional High Thrust

Product Code		Thrust N	Volume Flow Rate m ³ /s	Velocity m/s	Sound Pressure dBA @ 1m	Speed r/min	Motor Power kW	FLC Amps	SC Amps	Absorbed Power kW
JFU/F3-315-2-HAI	High	30	1.40	17.91	65	2875	1.27	2.73	14.5	0.91
	Low	10	0.81	10.34	47	1460	0.29	0.82	2.9	0.15
JFU/F3-355-2-HAI	High	50	2.03	20.52	70	2920	2.53	5.25	31.5	1.73
	Low	15	1.11	11.24	52	1475	0.58	1.68	5.4	0.23
JFU/F3-400-2-SAI	High	50	2.29	18.21	63	2835	1.27	2.73	14.5	0.95
	Low	16	1.29	10.30	47	1450	0.29	0.82	2.9	0.15
JFU/F3-400-2-HAI	High	80	2.89	23.03	69	2895	2.53	5.25	31.5	2.30
	Low	18	1.37	10.93	51	1465	0.58	1.68	5.4	0.30

Product Code	Dia.	A	B	C	D	E	F	G	H	J	K	L	Weight kg
JFU/F3-315	315	332	280	12	225	160	484	296	413	226	1686	442	58
JFU/F3-355	355	416	360	12	244	180	544	331	440	227	1694	444	79
JFU/F3-400	400	416	360	12	244	180	569	331	503	266	2192	520	98

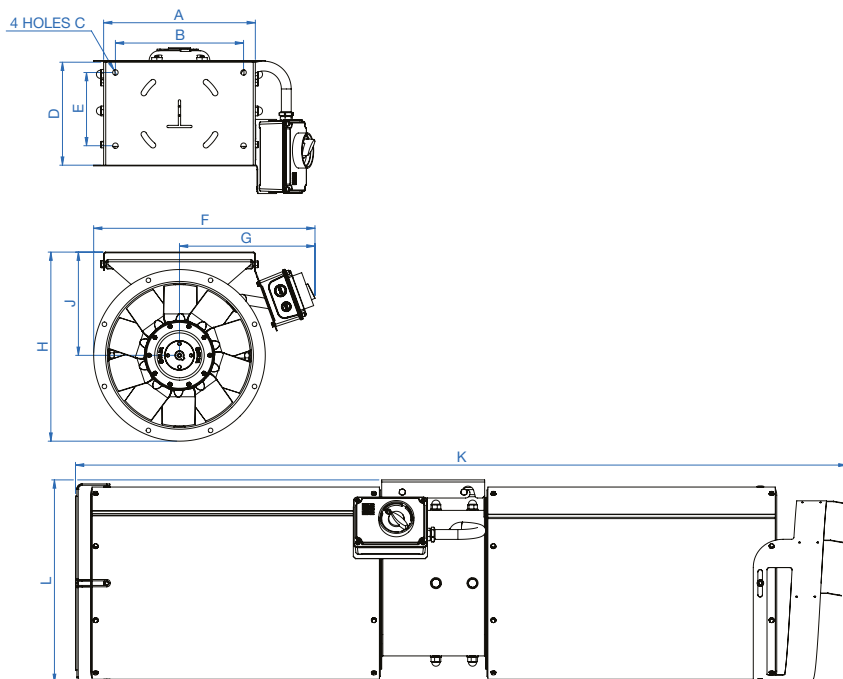

Flanged Units

JetVent Truly Reversible High Thrust

Product Code		Thrust N	Volume Flow Rate m ³ /s	Velocity m/s	Sound Pressure dBA @ 1m	Speed r/min	Motor Power kW	FLC Amps	SC Amps	Absorbed Power kW
JFR/F3-315-2-HAI	High	24	1.24	15.91	66	2895	1.27	2.73	14.5	0.86
	Low	6	0.63	8.08	48	1470	0.29	0.82	2.9	0.13
JFR/F3-355-2-HAI	High	43	1.89	19.07	70	2945	2.53	5.25	31.5	1.54
	Low	11	0.95	9.63	53	1490	0.58	1.68	5.4	0.23
JFR/F3-400-2-SAI	High	52	2.02	21.64	66	2841	1.3	2.41	14.5	1.17
	Low	16	1.02	10.87	57	1443	0.28	0.75	2.85	0.17
JFR/F3-400-2-HAI	High	83	2.61	26.42	72	2900	2.53	5.25	31.5	2.74
	Low	21	1.33	13.45	55	1475	0.58	1.68	5.4	0.42

Product Code	Dia.	A	B	C	D	E	F	G	H	J	K	L	Weight kg
JFR/F3-315	315	332	280	12	225	160	484	296	413	226	1806	437	60
JFR/F3-355	355	416	360	12	244	180	544	331	440	227	1816	442	81
JFR/F3-400	400	416	360	12	244	180	569	331	503	266	2345	520	100

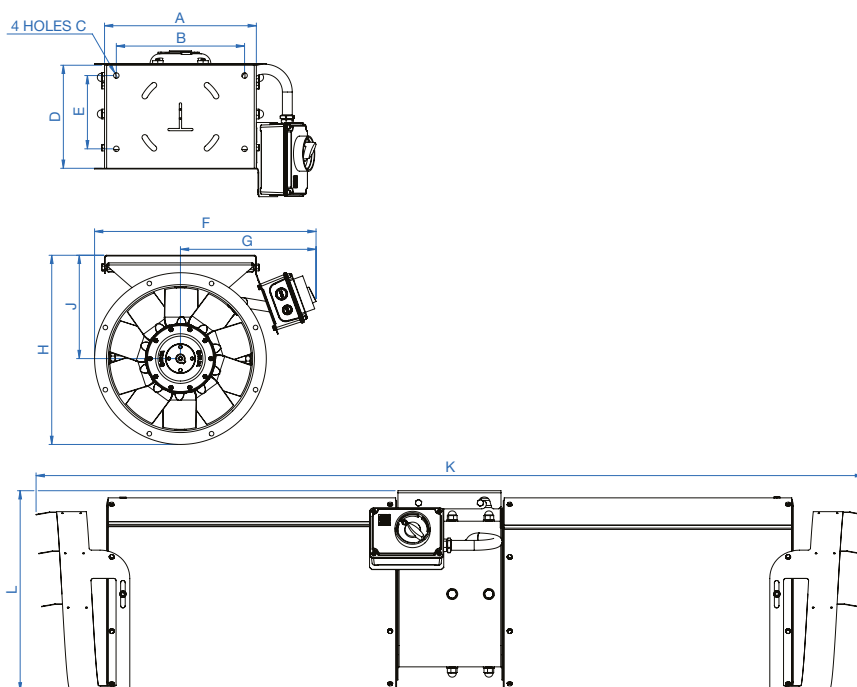

All dimensions are expressed in mm. All dBA figures shown are free field sound pressure levels at 45° to inlet/outlet. All starting currents shown are direct online (DOL). Air density used in all figures is 1.2kg/m³. Single speed options available. F200 & F400 variations available. Further details on request. Codes shown are for isolator versions. Terminal box version also available.

Performance & Dimensional Data

Unflanged Units

JetVent Unidirectional Standard Thrust

Product Code	Thrust N	Volume Flow Rate m ³ /s	Velocity m/s	Sound Pressure dBA @ 1m	Speed r/min	Motor Power kW	FLC Amps	SC Amps	Absorbed Power kW
JVSU-CPA-315 2-3	21	0.95	16.52	62	2960	0.80	1.91	11.46	0.45
JVSU-CPA-400 2/4-3	51/12	1.95/0.97	20.91/10.42	64/50	2855/1448	1.30/0.28	2.41/0.75	14.50/2.85	1.02/0.16

Product Code	A	B	C	D	E	F	G	H (max)	Weight kg
JVSU-CPA-315	380	450	350	400	25	14	335.5	1990	65
JVSU-CPA-400	380	450	395	445	25	14	427	2880	75

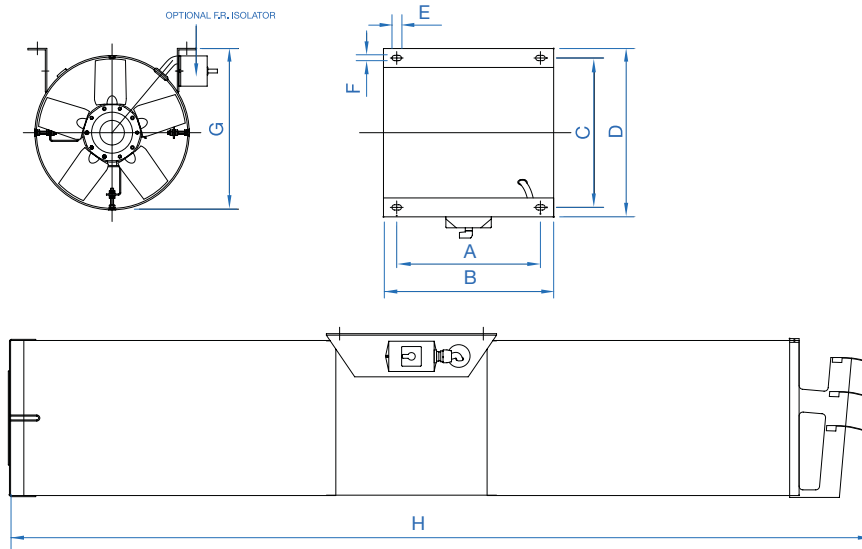

Unflanged Units

JetVent Truly Reversible Standard Thrust

Product Code	Thrust N	Volume Flow Rate m ³ /s	Velocity m/s	Sound Pressure dBA @ 1m	Speed r/min	Motor Power kW	FLC Amps	SC Amps	Absorbed Power kW
JVSR-CPA-315 2-3	20	0.96	16.73	64	2950	0.80	1.91	11.46	0.47
JVSR-CPA-400 2/4-3	52/13	2.02/1.02	21.64/10.87	55/57	2841/1443	1.30/0.28	2.41/0.75	14.50/2.85	1.17/0.17

Product Code	A	B	C	D	E	F	G	H (max)	Weight kg
JVSR-CPA-315	380	450	350	400	25	14	335.5	2098	65
JVSR-CPA-400	380	450	395	445	25	14	427	3030	75

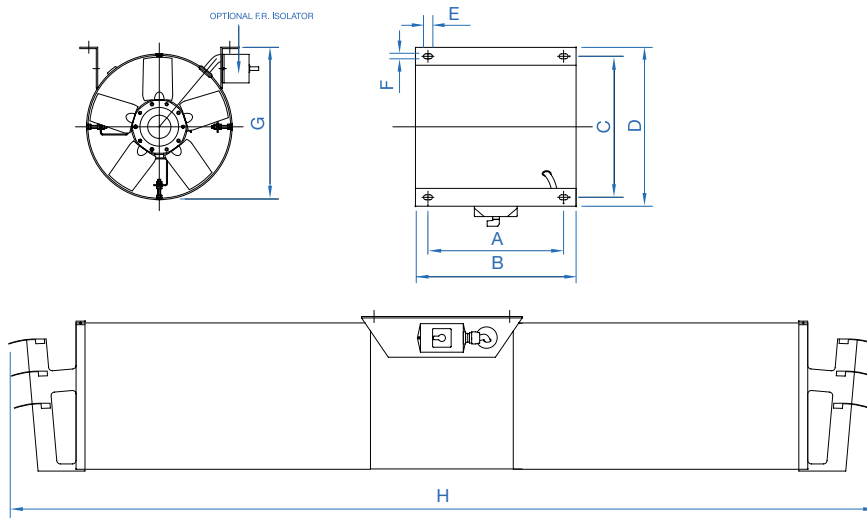

All dimensions are expressed in mm. Motors shown are suitable for the following: General use at temperatures (ambient) +40°C. One off high temperature use of 300°C for 2 hour. 400Volt / 3 Phase / 50Hz electrical supply. All thrust figures are measured under test conditions. Volume flow and velocity figures shown may have been calculated in accordance with test requirements. All the test data shown has been prepared in accordance with ISO 13350 1999 / BS 848-10-1999.





Induction Ventilation

The ventilation level to be provided within the car park (in order to limit the concentration of carbon monoxide and other vehicle emissions and to remove smoke in the event of a fire) can be found in the relevant Building Regulations and in BS 7346-7:2006 Components for smoke and heat control systems. Code of practice on functional recommendations and calculation methods for smoke and heat control systems for covered car parks.

The Principles of JetVent

JetVent induction fans have been specifically designed to provide a high velocity, laminar airflow in a reduced height profile to help overcome problems caused by obstructive structural beams and low overall ceiling heights found in car parks. The innovative design of JetVent induction fans provides major benefits in terms of reduced installation and running costs as well as effective smoke and contaminant removal.

The induction ventilation system is based on a number of small, strategically located high velocity fans in place of the large and expensive distribution ductwork traditionally used in car parks. Induction fans operate on well-proven tunnel ventilation principles, producing a high velocity jet which adds momentum to the air in front of the fan imparting thrust to all the surrounding air through mixing and entrainment as it diffuses. The volume of entrained air is significantly greater than that passing through the fan.

The induction fans are carefully positioned to direct the airflow towards the main extract fan intake points. The main extract fans are sized to provide the required flow rates, however, given the reduced need for, or complete elimination of ducting, the resulting reduction in system resistance means they are typically smaller and consume less energy.

Induction fan performance is rated in terms of the thrust developed by the fan, which is the product of the mass flow rate times the change in velocity, i.e. volume flow rate times the air density times the fan outlet velocity, and is measured in Newtons.

Conventional & Induction Ventilation

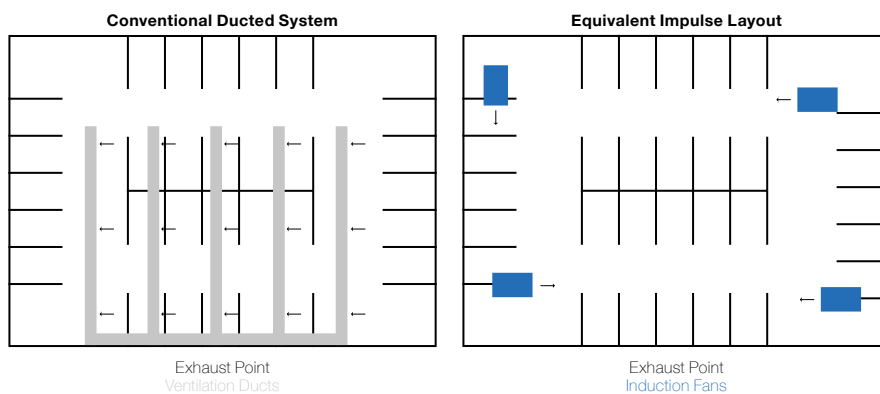

The distribution ducting used in traditional systems is replaced by a number of small JetVent centrifugal induction fans to direct the airflow across the designated area. Without the distribution duct resistance, smaller exhaust and supply fans and / or motors can be used.

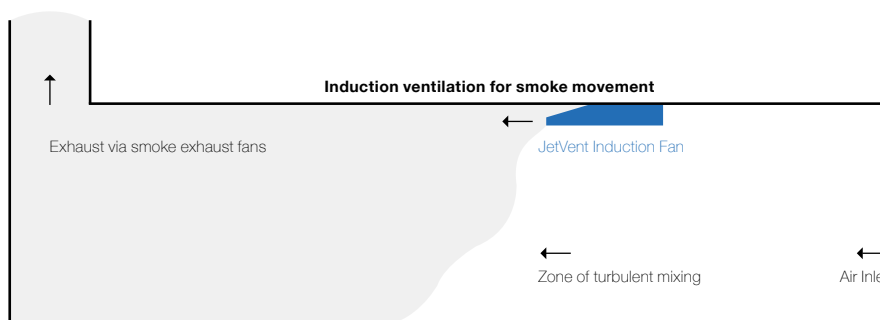

Features & Benefits

The JetVent centrifugal induction range comprises 50N or 100N thrust types that conform to European Standard EN12101-3. The range is suitable for ambient temperature operation as well as once only, 2 hour high temperature smoke conditions up to 400°C. The two speed motor is suitable for frequency inverter speed control on high speed.

Cost Effective

JetVent provides the scope for reduced installation and overall construction build costs compared with traditional ducted systems. The high efficiency impellers make this a very economical method of moving high volumes of air.

Rigorous Testing

JetVent is independently tested to meet the exacting standards of EN 12101-3 for operating at 300°C for 2 hours. Performance is tested to BS848 - 10:1999 Fans for general purposes - Performance testing of jet fans.

Air Quality

JetVent induction fans provide an improvement in air quality achieved by mixing the air more effectively, which means the potential risk of contaminant accumulation (beyond specific requirements) is overcome.

Ingress Protection

A minimum protection to IP55 on electrics improves reliability and ease of cleaning by means of pressure washing components. The unit is supplied as standard with a fitted IP55 terminal box or an optional lockable fire rated isolator.

Robust Design

The powder coated mild steel fan casing provides a robust construction, which is very resistant to potential corrosion. The integral guard is designed to protect against the rotating impeller parts. The guard is finger proof and bright zinc plated.

Slim Profile

The slim profile design of JetVent allows designers to overcome problems caused by obstructive structural beams and low overall ceiling heights, without compromising performance characteristics.

Better Security

The elimination or reduction in ductwork means a safer, lighter environment with better security due to the increased visibility.

Low Maintenance

With no ductwork, maintenance costs are reduced as there is no ducting to become blocked, damaged or subject to leakage.

Performance & Dimensional Data

Centrifugal

Product Code		Thrust N	Volume Flow Rate m ³ /s	Velocity m/s	Sound Pressure dBA @ 1m	Speed r/min	Motor Power kW	FLC Amps	SC Amps	Absorbed Power kW
JVC/F3B-50N-2-AI	High	54	1.62	28.82	67	1449	1.38	3.2	16	1.11
	Low	12	0.80	14.00	40	733	0.35	1.36	4.08	0.21
JVC/F3B-100N-2-AI	High	100	2.65	33.19	72	1425	2.7	6.03	30.15	2.31
	Low	18	1.35	16.84	55	729	0.68	2.26	7.23	0.43

Product Code	A	B	C	D	E	F	G	H	H	H	Weight kg
JVC/F3B-50N-2-AI	1359	380	790	102	836	880	27	12	273	75	113
JVC/F3B-100N-2-AI	1830	700	1147	102	1203	1247	27	12	332	70	146

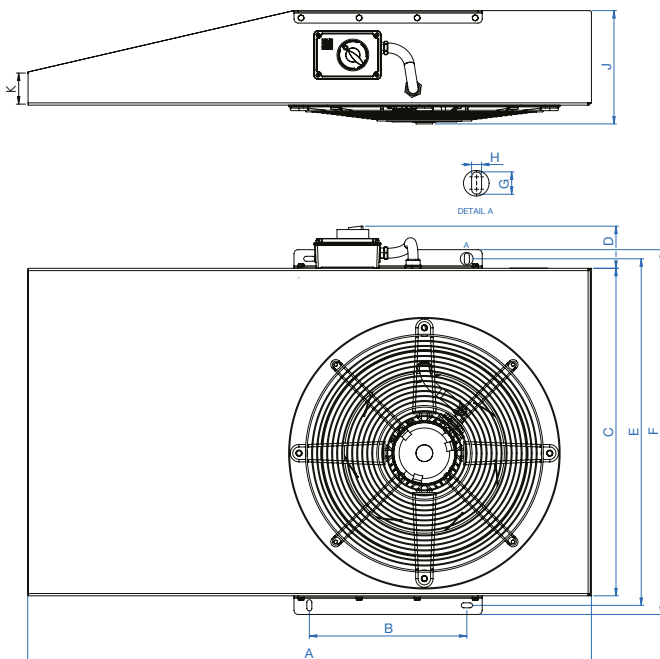

All dimensions are expressed in mm. Motors shown are suitable for the following: General use at temperatures (ambient) +40°C. One off high temperature use of 300°C for 2 hours. 400Volt / 3 Phase / 50Hz electrical supply. All thrust figures are measured under test conditions. Volume flow and velocity figures shown may have been calculated in accordance with test requirements. All the test data shown has been prepared in accordance with ISO 13350 1999 / BS 848-10-1999. dBA figures are free field sound pressure levels at 45° to the outlet.



Emergency Extract Ventilation

Elta Fans have been manufacturing fans for over 40 years and are one of the founding members of the Smoke Control Association, which has been instrumental in shaping modern legislation. We were also the first company to have our entire range accredited to EN12101-3 the standard to which all four of our sites across the world manufacture.

The SmokeVent range of axial flow fans has been specifically developed for emergency smoke spill extract systems to overcome hazardous fire, smoke and fume conditions. They may operate as part of the main extract system or as dedicated fans for emergency clearance.

Our fans are of especially high design and manufacturing integrity and are made bespoke for the individual demands of the application in order to assure the safety and operation of the structure and its occupants. As high temperatures and smoke particulates can damage components, our fans have been robustly designed for continued operation in this arduous environment.

SmokeVent Fans

Our comprehensive range of SmokeVent fans are supplied for free-standing operation in ducted systems and are also suitable for installation in roof extract units. All fans are designed in accordance with EN12101-3 standards and can also be supplied to meet additional region or project specifications as required.

With a broad range of sizes and variants we can flexibly supply models for new and refurbishment projects.

Please contact Elta Fans for more information on +44 (0)1489 566500.

Fan Selection Program

The Elta Fans Fan Selection Program has been designed to make fan selection faster and more efficient.

Developed from the ground up, the selection program makes it quicker and easier for you to select fans from our expansive range of products. Whether you've used the program previously or this is your first time, you will find this program a helpful part of your processes.

Navigating the Program

To navigate between the main areas of the program, simply use the main navigation buttons at the top. The program highlights the button to show which area of the program you are in. A dedicated help source is available with the ability to define common default settings.

Selecting a Fan

Basic mode: allows you to use a 5 step process to determine suitable fans, or alternatively, use a single Product Code.

Advanced mode: gives you complete control over the criteria for selecting your fan.

Silencers & Acoustic Analysis

Silencer selection is available in both basic and advanced modes allowing a simple 5 step process to determine a suitable silencer or complete control over the criteria of the silencer type required.

The acoustic analysis tool allows calculations on simple systems to be made to provide a rough approximation of what noise level can be expected.

Our Fan Selection Program has become the essential software for consultants and contractors who want fast and accurate fan and silencer selections.

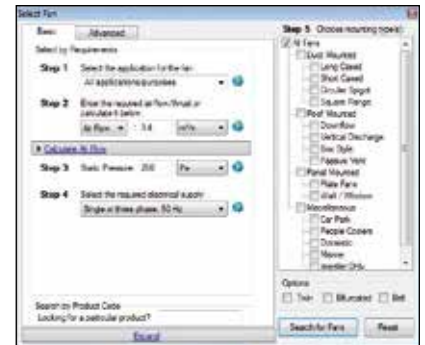

Basic Mode



Advanced Mode

Key Features

The latest version has been designed to make it easier for you to select, compare and schedule fans and silencers with a number of powerful new features that will help you save time.

- ✓ **A more user-friendly interface**
Easier to find what you need based on a wide choice of criteria
- ✓ **Basic and advanced user modes**
With guidance, use the program at the level that suits you
- ✓ **Revolutionary support for variable speed fans**
Helps you design more energy efficient systems
- ✓ **Store all 2D .dwg and .dxf**
For a project in a folder in one quick step
- ✓ **Conveniently view technical data**
In a single screen and recall it at any time
- ✓ **Easily select energy efficient fans**
And calculate running costs
- ✓ **Fully integrated PDF and Excel output**
Promoting the efficient electronic flow of data and further compliment paperless offices

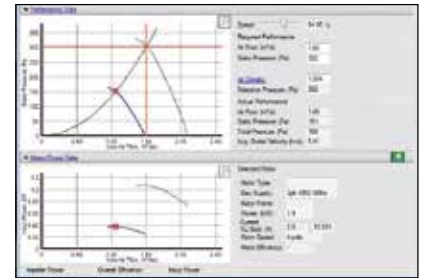

Revolutionary Support

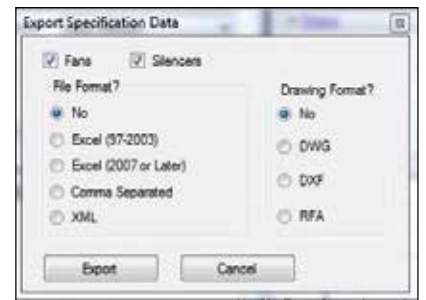

Store All Files

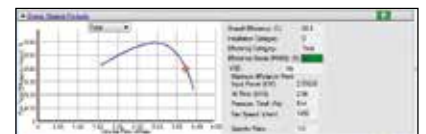

Product	Type	Da	Spd	WdP	WdS	TSP	dB(A)	Cost	FMES
LC28K16P20	Lamp-Casell A	630	1440	0.76	400	72%	62	79	88
LC28K16P18	Lamp-Casell A	630	1440	1.1	400	55%	65	81	83
SPR302-0-1200	Comes-Rotom	630	1170	2.2	415		71	102	62
LC28K16P17	Lamp-Casell A	630	1440	1.1	400	55%	65	81	83
LC28K16P16	Lamp-Casell A	630	1440	1.1	400	55%	65	81	83
LC28K16P15	Lamp-Casell A	630	1440	1.1	400	55%	65	81	83
LC28K16P14	Lamp-Casell A	630	1440	1.1	400	55%	65	81	83
LC28K16P13	Lamp-Casell A	630	1440	1.1	400	55%	65	81	83
LC28K16P12	Lamp-Casell A	630	1440	1.1	400	55%	65	81	83
LC28K16P11	Lamp-Casell A	630	1440	1.1	400	55%	65	81	83
LC28K16P10	Lamp-Casell A	630	1440	1.1	400	55%	65	81	83

Select Efficient Fans

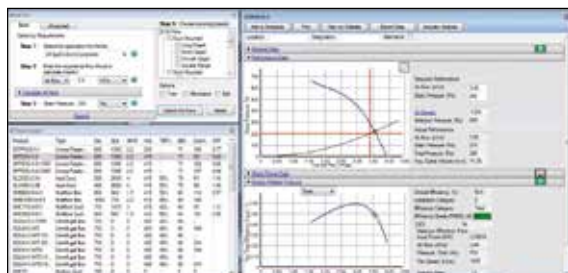

Convenient Data View



PDF Output

Customer Service

At Elta Fans, we pride ourselves on our integrity and reliability as a supplier. We respect that this is your project. To ensure that your project is the best it can be, when working with us, you get a partnership with as much or as little involvement from us as you need.

We have a dedicated sales team with individuals who are specifically trained to be experts in their individual market. When you place an order with us, you are allocated a direct point of contact to ensure consistency throughout the sales process. Our dedicated projects team constantly monitor projects, giving customers updates on their order as often as they need them.

From order processing to manufacture and all the way through to delivery, our dedicated aftersales team follow an established process to ensure we don't lose visibility of the project at any stage.



Certifications

Elta Fans are committed to conforming to the highest standards. We hold a number of internationally recognised accreditations and certifications, in accordance with EN12103-3, including:

[Kite Mark KM613754](#)

[LPCB C937a-05](#)

[Certificate of Constasy of Performance 0086-CPR-493001](#)

LPCB third party product certification schemes are quality assurance schemes comprised of full testing of a manufacturer's quality system and production procedures, regular audit testing, labelling and listing. LPCB certified products are accepted throughout the UK and around the world.

We are also active members of professional organisations that help to shape and direct the research, legislation, trends and issues of the present and future including:

[FETA](#)

[FMA](#)

[EVIA](#)

[CIBSE Patrons](#)

[HEVAC Association](#)

[BSRIA](#)

[AMCA](#)

[Smoke Control Association](#)

Smoke Control Association

The Smoke Control Association (SCA) is an independent body of experts all involved in various aspects of the smoke control sector. The association works in many fields including the publication of guides related to smoke control systems and products.

During the past 10 years, these guides have included methods for testing smoke extract fans, natural ventilators and smoke curtains which were subsequently adopted by BSI in the BS 7346 range of standards, ultimately being embraced in the EN12101 European Standards series.

All Elta Fans welders involved in the manufacture of JetVent products are coded to:

[ASME Boiler & Pressure Vessel Code](#)

Section IX (welding procedure qualification records & individual welder performance qualifications).

[BS ISO 15614-1:2004 A2:2012](#)

Welding procedure qualifications records.

[ISO 9606-1:2013](#)

Individual welder performance qualifications.

17 Barnes Wallis Road, Segensworth East Industrial Estate,
Fareham, Hampshire, PO15 5ST, United Kingdom

Tel: +44 (0) 1489 566500 **Fax:** +44 (0) 1489 566555

Email: at@eltofans.co.uk **Website:** www.eltofans.com

A MEMBER OF  ELTA
GROUP