

# Frascold<sup>®</sup>

## CO<sub>2</sub>

**Frascold semi-hermetic reciprocating compressors**  
for CO<sub>2</sub> subcritical and transcritical applications

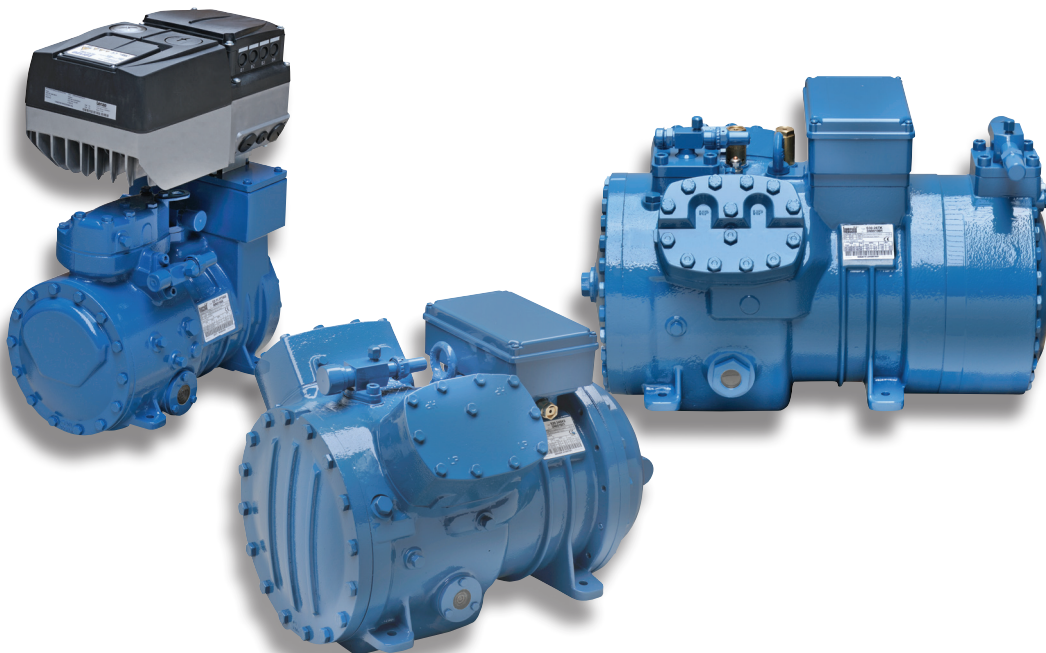

# SK2 SERIES

The SK2 series of compressors for CO<sub>2</sub> subcritical applications has been developed taking into consideration the most recent requirements coming from industrial refrigeration and from manufacturers of supermarket refrigeration systems. Thanks to high design pressures these compressors can be installed in the most common cascade and booster systems with standstill pressures up to 60bar.

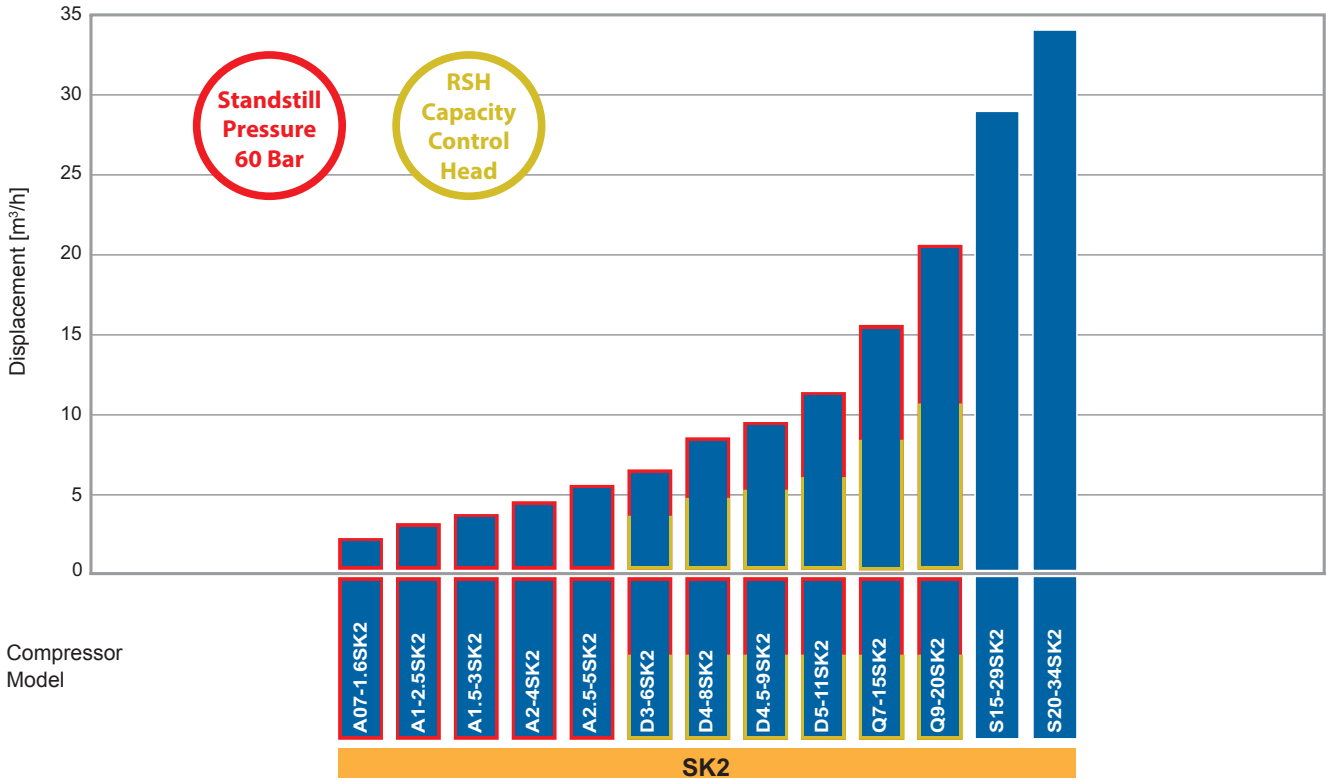

## Model designation

### Compressor

<b>Family Series</b>	A - D - Q - S
<b>Motor Size</b>	0,7 to 20 HP
<b>Displacement</b>	1,6 to 34 m³/h at 50 Hz
<b>Application</b>	CO <sub>2</sub> Subcritical

**D 4.5 - 9 SK2**

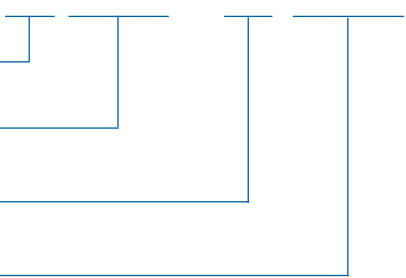

## Standard extent of delivery

The SK2 range of compressors are supplied complete with suction and discharge valves with welded connections, internal bypass valve, external safety valve, rubber vibration dampers, POE lubricant charge, nitrogen protective charge, oil level sight glass, electronic protection module Kriwan INT69® Diagnose.

### Main features

- Maximum condensing temperature: 15°C (55bar).
- Maximum allowable standstill pressure  $p_{ss}$  = 30bar; models with  $p_{ss}$  = 60bar are available upon request.
- Suitable for operation with variable frequency drive.
- The whole range is supplied with POE 85 oil.
- The whole range is supplied with Kriwan protection module INT69® Diagnose
- Discharge temperature sensor available for Q and S models upon request.
- RSH capacity control head available for D and Q series.

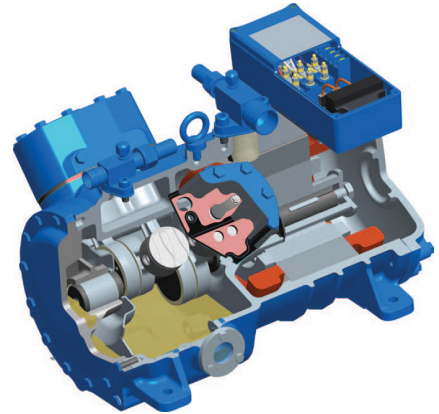

### Application

- Cascade systems (R134a / R407F / HFO in combination with CO<sub>2</sub>).
- Booster systems.

### Operating limits

R744

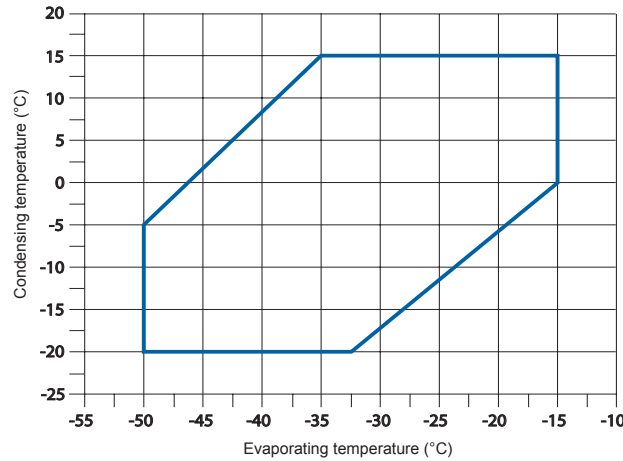

Application limits based on suction superheat 10K.

### RSH Capacity control head

One of the main advantage on using an SK2 compressor for CO<sub>2</sub> subcritical application is the possibility to operate with capacity control systems: in addition to the use of a variable frequency drive Frascold developed a unique and advanced capacity control head which provides to the system different levels of cooling capacity. This innovative device has been developed with the utmost attention to stabilize the suction pressure during the normal system operation and to follow the fluctuation of the thermal load; the outcome is a significant reduction of the switching on-off cycles and a better efficiency and reliability of the system. At present the new RSH head is available for all models of D and Q series.



RSH - D Series	
100%	
50%	

Valve de-energized      Valve energized

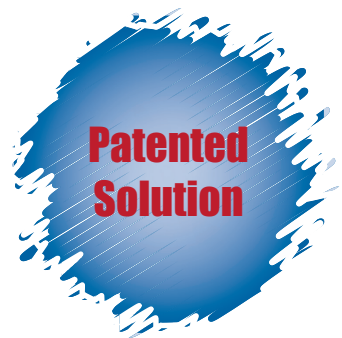

# TK SERIES

The TK series of compressors for CO<sub>2</sub> transcritical applications has been developed to meet the latest needs of refrigeration and heating technologies. These compressors are suitable for use in CO<sub>2</sub> transcritical applications single-stage and booster (in combination with SK2 compressors series).

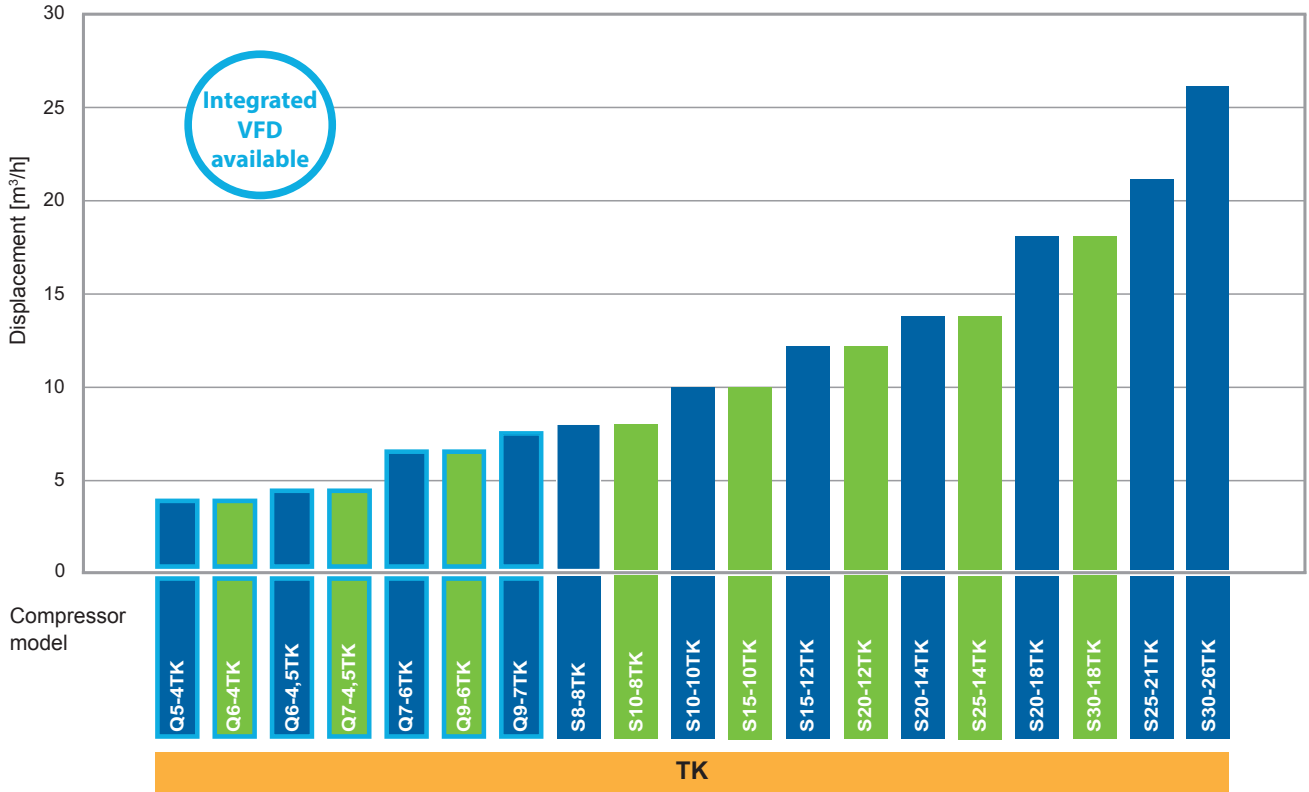

- Models optimised for refrigeration applications (Motor 2).
- Models also suitable for heat pumps (Motor 1).

## Model designation

### Compressor

<b>Family Series</b>	Q - S
<b>Motor Size</b>	5 + 30 HP
<b>Displacement</b>	4 + 26 m³/h at 50 Hz
<b>Application</b>	CO <sub>2</sub> Transcritical

**S 25 - 14 TK**

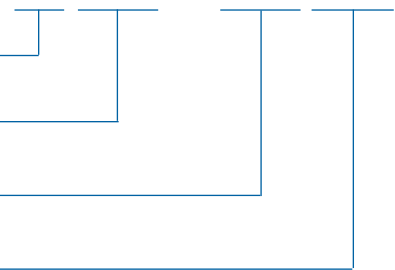

## Standard extent of delivery

TK range's compressors are supplied complete with suction and discharge copper plated valves suitable for weld connections (discharge valve suitable for steel pipe connection is available upon request), external pressure relief valve on both discharge and suction side, discharge temperature sensor, vibration dampers, lubricant charge, nitrogen protective charge, oil level sight glass, electronic protection module Krivan INT69® Diagnose.

### Main features

- 11 models optimised for refrigeration applications.
- 8 models also suitable for heat pumps as well as refrigeration applications.
- Maximum allowable pressures: discharge side  $p_s = 140\text{bar}$ , suction side  $p_s = 80\text{bar}$ .
- Suitable for operation with variable frequency drive.
- Model optimised for refrigeration applications are supplied with POE 85 oil; model optimised for heat pumps are supplied with PAG 68 oil.
- The whole range is supplied with Kriwan protection module INT69® Diagnose.
- Discharge temperature sensor is supplied with all compressors.
- Water cooled head available for all models of S series.
- Integrated variable frequency drive available for all models of Q series.

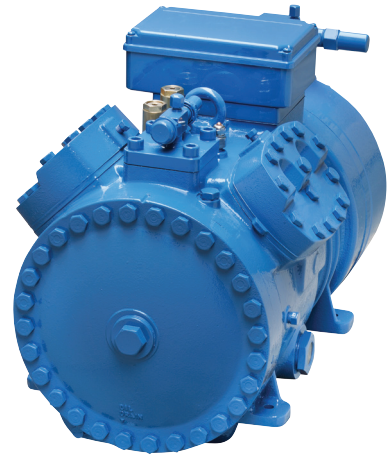

### Application

- Commercial refrigeration medium - high temperature
- Booster systems.
- Heat pumps.
- Reversible systems.

### Operating limits

#### R744

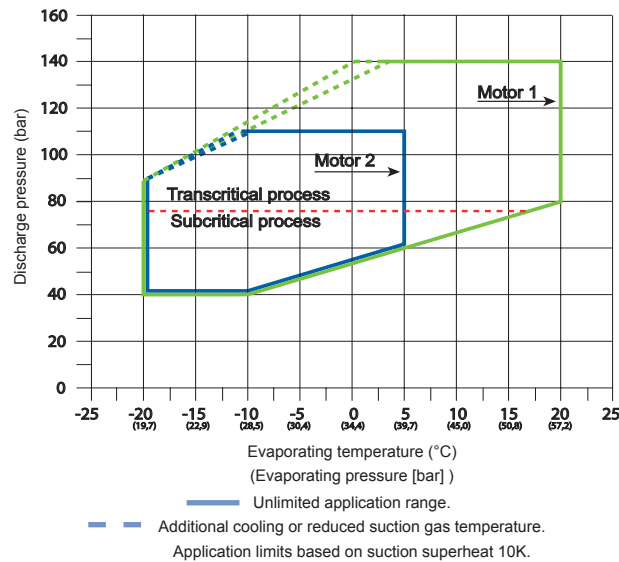

### Transcritical two-stage compressor

The new model Q9-5.3STK is a two-stage CO<sub>2</sub> transcritical compressor designed to operate in a flash-gas by-pass cycle with one temperature level or two different levels, medium and low temperature. At the evaporating temperature -30°C and discharge pressure 87bar, with gas cooler outlet temperature 35°C, the compressor is able to provide a cooling capacity of about 8kW.

### Main features

- 1<sup>st</sup> stage displacement 5,3m<sup>3</sup>/h, 2<sup>nd</sup> stage displacement 3,5m<sup>3</sup>/h .
- Nominal motor size 9HP.
- Number of cylinders: 2+2.
- Maximum allowable pressures: discharge side  $p_s = 140\text{bar}$ , suction side  $p_s = 80\text{bar}$ .
- POE 85 oil.

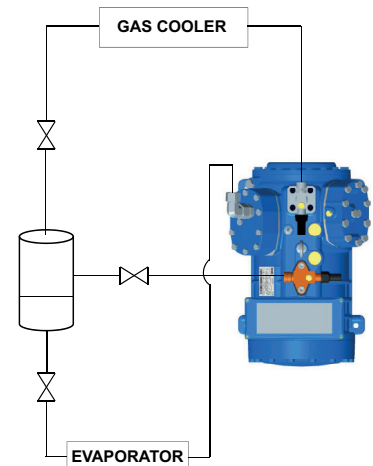
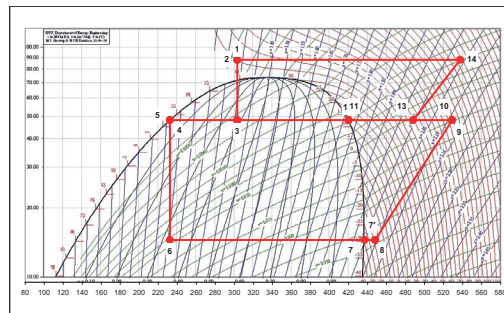

# CALORIMETRIC PLANT FOR SUBCRITICAL AND TRANSCRITICAL COMPRESSOR TESTING

Among the several calorimetric plants which make up Frascold laboratories one is dedicated to test the performance of CO<sub>2</sub> compressors for both subcritical and transcritical applications; this plant has been completely redesigned in order to be suitable to test a wider range of cooling capacities according to the most recent requirements coming from the refrigeration industry.

The refrigerant circuit of the calorimetric plant has been enlarged and based on a cascade system. An internal economiser on the bottom stage ensures maximum energy saving, evaporating the liquid by using the discharge mass flow; when a transcritical compressor is tested, the condensing heat corresponding to the compressor power input is removed from the bottom stage through a water cooled gas cooler; in case of subcritical compressor testing it is done through the heat exchanger, R134a/CO<sub>2</sub>, placed between the two stages.

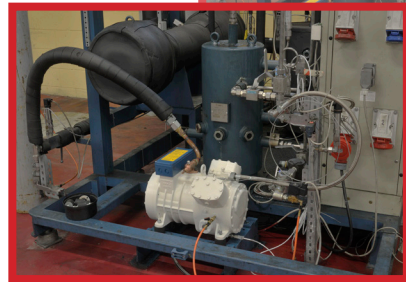
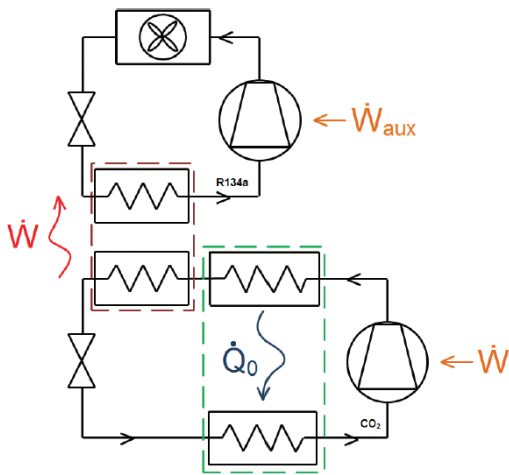
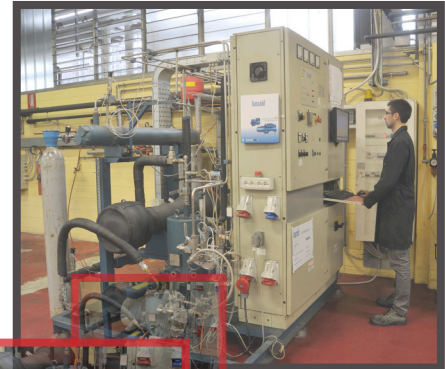

- $\dot{W}$  Compressor power input in the bottom stage.
- $\dot{W}_{aux}$  Compressor power input in the top stage.
- $\dot{Q}_0$  Evaporating heat in to the economiser.

The expansion is made in two phases, a first expansion after the gas cooler and a second one after the liquid receiver (flash gas tank), this relieves the system of pressure regulation in the gas cooler and in the liquid receiver. The whole plant is self controlled through a PID control used by a PLC.

A dedicated software was implemented to display the cycle parameters and to set the measuring points. Once the input parameters are fixed and the circuit is stabilized, the system calculates efficiency values and COP of the compressor. The outcome of the performance test are also used as input data for the calculation and the selection performed by Frascold CO<sub>2</sub> selection software.

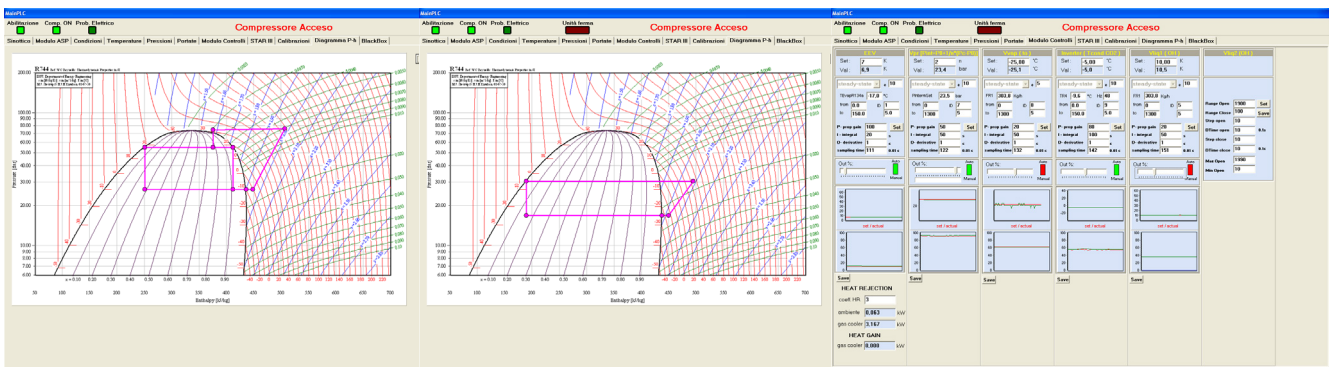



# FRASCOLD SELECTION SOFTWARE – CARBON DIOXIDE

A completely new selection software dedicated to carbon dioxide cycles has been designed and developed by Frascold technical department with the utmost attention to support all customers on defining and selecting, for several different kind of CO<sub>2</sub> cycles, Frascold CO<sub>2</sub> subcritical and transcritical models, as well as checking cycles performance. Starting the selection, the following CO<sub>2</sub> cycles are available:

- Basic cycle without flash-gas.
- Flash-gas by-pass cycle with one medium temperature level.
- Flash-gas by-pass cycle with two medium temperature levels.
- Flash-gas by-pass cycle with three medium temperature levels.
- Booster cycle with one medium temperature level.
- Booster cycle with two medium temperature levels.
- Booster cycle with three medium temperature levels.

For all booster cycles an additional gas cooler can be placed in the discharge line of the booster compressor.

Once a specific CO<sub>2</sub> cycle is selected, it is possible to choose among three different calculation routines, each one requires dedicated input parameters and provide different outcomes:

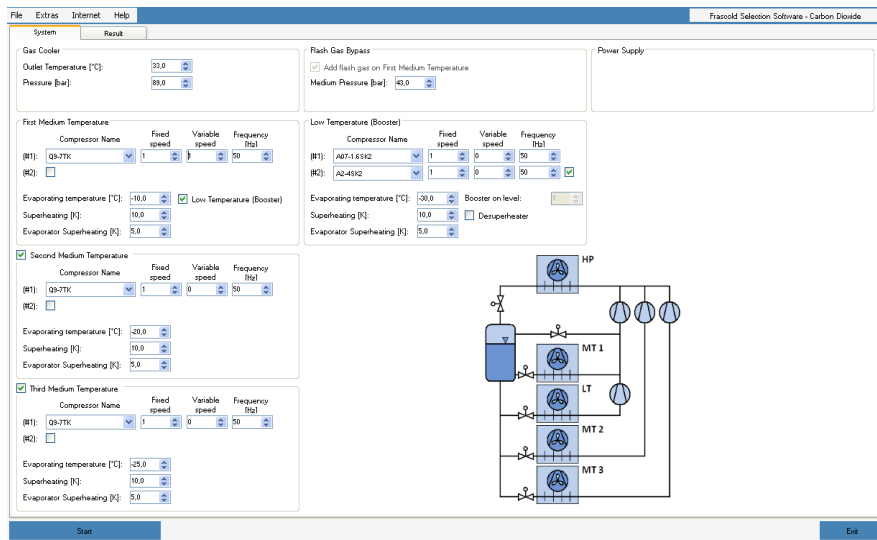

- Check calculation: according to the compressor type (model and number) defined for each temperature level the software calculates the cooling capacity of each stage and the heat exchanged on the gas cooler.
- Dimensioning calculation: once defined the compressor models for each temperature level and the cooling capacity of each stage the software calculates the number of compressors for each temperature level (one of them driven by variable frequency drive).
- Selection: according to the cooling capacity of each stage and the number of compressors with fixed speed and driven by variable frequency drive the software provides two outcomes: the closest to the cooling capacity target with all compressors switched on and variable frequency drive compressors at the maximum speed; the closest to the cooling capacity target with all compressors switched at the nominal speed.

According to the system input parameters the defined working cycle is displayed together with the calculation outcome.

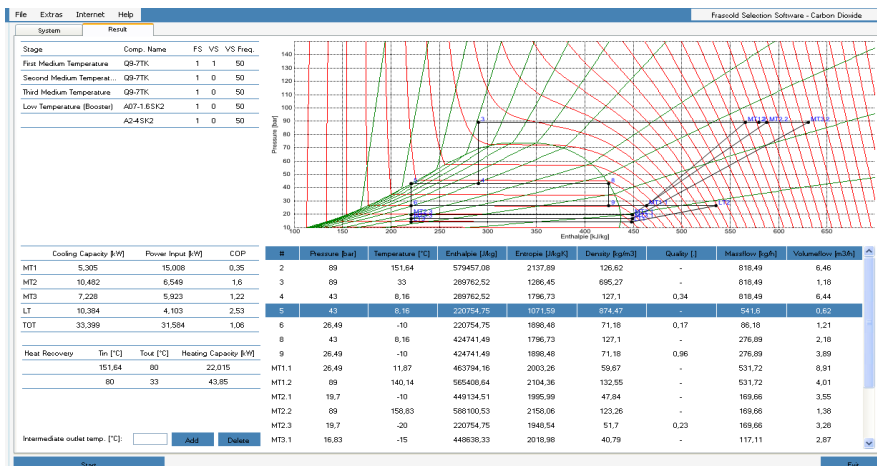

# FRASCOLD®

A company with more than 75 years of experience manufacturing compressors for refrigeration and air conditioning industries. The wide experience gained over the years provides cutting-edge products and solutions, in line with the latest demands of the market. Our product range has available a wide range of options to meet the specific application and market needs worldwide, always paying attention to the energy efficiency and in full respect of the environment. All quality and construction directives indicated by the relevant authorities are strictly followed.

## **FRASCOLD SpA**

Via B. Melzi 105 - 20027 Rescaldina (MI) Italy

Tel. +39 0331 742201 - Fax +39 0331 576102

mail: [frascold@frascold.it](mailto:frascold@frascold.it) - web: [www.frascold.it](http://www.frascold.it)