

FASCOLD

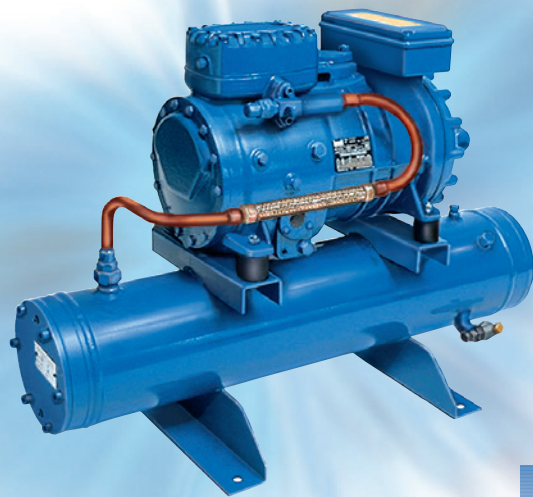

SH

WATER COOLED CONDENSING UNITS

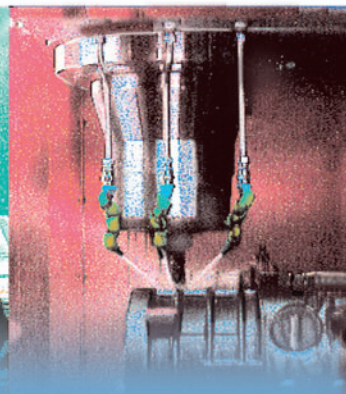

- **FRASCOLD SpA** si riserva il diritto di modificare i dati e le caratteristiche contenute nel presente catalogo, senza obbligo di preavviso.
- **FRASCOLD SpA** reserves the right to change at any time, specifications or design without notice and without incurring obligations.
- **FRASCOLD SpA** se réserve le droit de modifier sans préavis les données et les caractéristiques contenues dans cette notice.
- **FRASCOLD SpA** behält sich das Recht vor Spezifikationen oder Ausführungen jederzeit ohne Bekanntgabe zu ändern.

Unità condensatrici ad acqua water cooled condensing units Groupes de condensation à eau Wassergekühlte Verflüssigungssätze

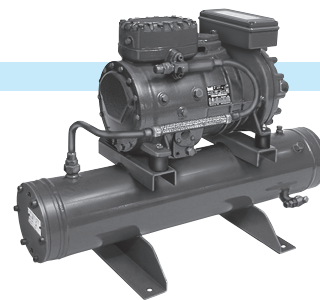

Dotazione standard

Le unità condensatrici sono essenzialmente composte da compressore semiermetico, condensatore ad acqua con attacco per valvola di sicurezza, rubinetti, basamento, e, a seconda del modello, antivibrante sulla linea di compressione.

Accessori

A richiesta, le unità condensatrici serie **SH** possono essere fornite complete di resistenza per il riscaldamento dell'olio nel carter del compressore, dispositivo per il controllo della capacità, dispositivo per la partenza a vuoto.

Capacità frigorifere

Le condizioni di calcolo delle prestazioni delle unità FRASCOLD sono illustrate a pagina 4 e pagina 5 "Capacità frigorifere".

Per tutti gli utilizzatori di prodotti FRASCOLD, è disponibile un software, su CD-ROM, che consente di prendere visione di tutti i dati illustrati nel presente catalogo e di selezionare il prodotto più adatto in base alle specifiche esigenze del progetto.

Compressori

Le unità condensatrici serie **SH** sono dotate di compressore di tipo semiermetico raffreddato dal gas aspirato, completo di rubinetti, attacchi di servizio, spia di livello olio, filtro di aspirazione, carica di olio, supporti antivibranti in gomma e teste con attacchi per raffreddamento ad acqua. Per maggiori dettagli tecnici, consultare il catalogo FCAT01 "Compressori semiermetici".

Condensatori ad acqua

I condensatori ad acqua che equipaggiano le unità condensatrici serie **SH** sono ad alta efficienza, abbondantemente dimensionati.

Sono costruiti con mantello e piastre tubiere in acciaio al carbonio, tubi in rame con alettatura integrale.

Gli attacchi lato acqua consentono il collegamento per alimentazione sia con acqua di pozzo che con acqua di torre evaporativa.

Standard equipment

Condensing units are essentially composed of semi-hermetic compressor, water cooled condenser with safety valve connection, service valves, base frame and depending by the model vibration absorber installed on discharge line.

Accessories

On request, **SH** condensing units can be supplied with crankcase oil heater, capacity control device, unloaded start device.

Refrigerating capacities

Units performances are calculated at the operative conditions quoted at page 4 and page 5 "Refrigerating capacity".

Electronic catalog is available, a software on CD-ROM that features all the data introduced in this catalogue and allows to select the correct product according to the specific operating conditions. Available free of charge to all users of FRASCOLD products.

Compressors

SH condensing units are equipped with semi-hermetic compressor cooled by suction refrigerant, complete with valves, pressure connections, oil sight glass, suction filter, oil charge, rubber vibration absorbers and water cooled heads.

For further technical details, see the catalogue FCAT01 "Semi-hermetic reciprocating compressors".

Water cooled condensers

Water cooled condenser of **SH** units is of high efficiency design with generous dimensions.

Shell and tube sheet are made of carbon steel, tubes in copper with integrally finned thick wall.

Water side connections allow supply both with mains water and cooling tower water.

Dotation standard

Les groupes de condensation se composent de compresseur semi-hermétique, condenseur à eau avec connexion pour soupape de sûreté, robinets d'isolement, châssis et éliminateur de vibrations au refoulement.

Accessoires

Les groupes de condensation **SH** peuvent être fournis d'une résistance de carter pour le chauffage de l'huile, d'un contrôle de capacité et d'un démarrage à vide.

Puissance frigorifique

Les conditions calcul des données des groupes FRASCOLD son illustrées à la page 4 et à la page 5 "Puissance frigorifique".

Pour tous les utilisateurs des produits FRASCOLD, sont disponibles un catalogue électronique; un software sur CD-ROM permettant de connaître toutes les données illustrées dans le catalogue et de sélectionner le produit le plus approprié selon les exigences particulières du projet.

Compresseurs

Semi-hermétiques, refroidis par les gaz aspirés, ils sont équipés de robinets, prises de pression, voyants de niveau d'huile, filtre aspiration, charge d'huile, supports anti-vibrations en caoutchouc et coulisses avec connexions pour refroidissement à eau. Pour plus de détails, voir le catalogue FCAT01 "Compresseurs semi-hermétiques".

Condenseurs à eau

D'une grande efficacité, largement dimensionnés, ils sont construits avec virole et plaque tubulaires en acier au carbone, tubes en cuivre à ailettes intégrales.

Les raccords coté eau permettent le branchement pour alimentation avec de l'eau de ville et aussi le branchement pour alimentation avec de l'eau de tour de refroidissement.

Lieferumfang

Die Verflüssigungssätze beinhalten halbhermetische Verdichter, wassergekühlte Verflüssiger, Grundrahmen und bei bestimmten Typen druckseitig Schwingungsdämpfer.

Zubehör

Als Zubehör ist erhältlich: Kurbelwellenheizung, Ölabscheider, Flüssigkeitsabscheider, HD/ND-Schalter, sowie Flüssigkeitseinspritzung. Bei bestimmten Typen ist weiterhin eine Anlaufentlastung sowie Leistungsregelung lieferbar.

Kälteleistungsangaben

Die Angaben der Leistung der FRASCOLD Verflüssigungssätze sind von Seite 4 bis Seite 5 "Kälteleistungsdaten" illustriert.

Für die Benutzer von FRASCOLD Produkten steht der Elektronische Katalog zur Verfügung; eine Software auf CD-ROM mit allen Katalogdaten, die Auswahl des richtigen Produktes nach den jeweiligen Betriebsbedingungen gestattet.

Verdichter

Halbhermetisch, sauggasgekühlt komplett mit Ventilen, Anschlüsse für Hoch- und Niederdruck, Ölschauglas, Saugfilter, Ölfüllung, Schwingungsdämpfern und Wassergekühlten Zylinderköpfen.

Weitere Einzelheiten siehe Katalog FCAT01 "Halbhermetische Verdichter".

Verflüssiger

Großzügig dimensionierter Hochleistungsverflüssiger aus Kohlenstoffstahl. Kupferrohre außen berippt. Wasserseitige Anschlüsse für Brauch.- oder Kühlturm-Wasser.

Dati tecnici
Technical data
Données techniques
Technische Daten

Unità condensatrice Condensing unit Groupe de condensation Verflüssigungssatz	Modello del compressore Compressor model Compresseur Verdichter	Carica massima di refrigerante Maximum refrigerant charge Charge maximum de réfrigérant Maximale Kältemittelfüllung				Disegno Drawing Plan Zeichnung	
		❶					❷
		R404A/R507A kg	R407C kg	R22 kg	R134a kg		
SH 0.7 5 A - Y	A 0.7 5 - Y	8.6	9.5	10.0	10.1	1	
SH 1 6 A - Y	A 1 6 - Y	8.3	9.2	9.6	9.8	1	
SH 1.5 7 A - Y	A 1.5 7 - Y	8.3	9.2	9.6	9.8	1	
SH 1.5 9 B - Y	B 1.5 9 - Y	8.3	9.2	9.6	9.8	1	
SH 2 11 D - Y	D 2 11 - Y	8.3	9.2	9.6	9.8	1	
SH 2 13 D - Y	D 2 13 - Y	8.3	9.2	9.6	9.8	1	
SH 3 13 D - Y	D 3 13 - Y	14.8	16.3	17.2	17.4	1	
SH 4 16 D - Y	D 4 16 - Y	14.8	16.3	17.2	17.4	1	
SH 3 18 D - Y	D 3 18 - Y	14.8	16.3	17.2	17.4	1	
SH 5 19 F - Y	F 5 19 - Y	14.8	16.3	17.2	17.4	2	
SH 4 24 F - Y	F 4 24 - Y	14.8	16.3	17.2	17.4	2	
SH 5 25 Q - Y	Q 5 25 - Y	14.8	16.3	17.2	17.4	3	
SH 7 28 Q - Y	Q 7 28 - Y	14.0	15.4	16.3	16.5	3	
SH 5 33 Q - Y	Q 5 33 - Y	14.0	15.4	16.3	16.5	3	
SH 7 33 Q - Y	Q 7 33 - Y	14.0	15.4	16.3	16.5	3	
SH 7 39 S - Y	S 7 39 - Y	14.0	15.4	16.3	16.5	4	
SH 10 39 S - Y	S 10 39 - Y	15.4	17.0	18.0	18.2	4	
SH 10 51 S - Y	S 10 51 - Y	15.4	17.0	18.0	18.2	4	
SH 15 51 S - Y	S 15 51 - Y	15.4	17.0	18.0	18.2	4	
SH 20 56 S - Y	S 20 56 - Y	15.4	17.0	18.0	18.2	4	
SH 15 71 V - Y	V 15 71 - Y	15.4	17.0	18.0	18.2	5	
SH 20 84 V - Y	V 20 84 - Y	19.8	21.8	23.1	23.4	5	
SH 30 84 V - Y	V 30 84 - Y	19.8	21.8	23.1	23.4	5	

❶ condensatore riempito al 80% con refrigerante liquido a +32°C
condenser filled to 80% with liquid refrigerant at +32°C
à +32°C température de liquide et 80% contenance du condenseur
bei +32°C Flüssigkeitstemperatur und 80% Behälterinhalt

❷ disegni da pagina 10 a 12
drawings from page 10 to 12
plans de page 10 à 12
Zeichnungen von Seite 10 bis 12

Capacità frigorifere

Le capacità frigorifere, riportate nelle tabelle da pagina 6 a pagina 9, sono state calcolate alle seguenti condizioni:

- sottoraffreddamento del liquido 5 K
- temperatura di condensazione come indicato
- **temperatura del gas aspirato 20°C**

R407C - Le temperature di evaporazione e di condensazione considerate sono relative al vapore saturo, in conformità con la norma EN12900.

Refrigerating capacity

Refrigerating capacities shown in page 6 up to page 9 are based on the following conditions:

- liquid subcooling 5 K
- condensing temperature as shown
- **suction gas temperature 20°C**

R407C - Evaporating and condensing temperatures are based on dew temperature, according to EN12900 standard.

Puissances frigorifiques

Les puissances frigorifiques, reportées sur les tableaux de la page 6 à la page 9, ont été calculées selon les conditions suivantes:

- sous-refroidissement du liquide 5 K
- température de condensation indiquée
- **température du gaz aspiré 20°C**

R407C - les températures d'évaporation et de condensation se réfèrent au point de rosée, in conformité avec la norme EN12900.

Kälteleistungsdaten

Die auf den Seiten 6 bis 9 gezeigten Kälteleistungen basieren auf den folgenden Bedingungen:

- Flüssigkeitsunterkühlung 5 K
- Verflüssigungstemperatur wie gezeigt
- **Sauggastemperatur 20°C**

R407C - Verdampfungs- und Verflüssigungstemperaturen beziehen sich auf Taupunkt-Werte, erfüllen die Forderung EN12900.

Collegamenti lato acqua

Water side connections

Raccord côté eau

Anschlüsse wasserseitig

CW

Collegamento per alimentazione con acqua di torre evaporativa
Connection for cooling tower water supply
Connection pour prise d'eau de tour de refroidissement
Verbindung zur Versorgung mit Kühlturmwasser

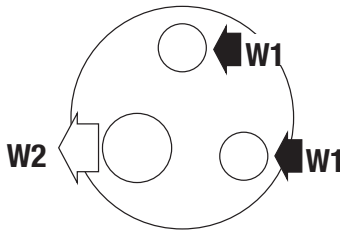

MW

Collegamento per alimentazione con acqua di pozzo
Connection for mains water supply
Connection pour prise d'eau de ville
Verbindung zur Versorgung mit Stadtwasser

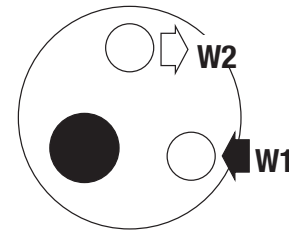

Unità condensatrice Condensing unit Groupe de condensation Verflüssigungssatz	Collegamento Connection Connection Verbindung		Collegamento Connection Connection Verbindung	
	CW		MW	
	ingresso inlet entrée Eintritt	uscita outlet sortie Austritt	ingresso inlet entrée Eintritt	uscita outlet sortie Austritt
	W1 "FPT"	W2 "FPT"	W1 "FPT"	W2 "FPT"

SH 0.7 5 A - Y	2 x 3/4"	1.1/4"	3/4"	3/4"
SH 1 6 A - Y	2 x 3/4"	1.1/4"	3/4"	3/4"
SH 1.5 7 A - Y	2 x 3/4"	1.1/4"	3/4"	3/4"
SH 1.5 9 B - Y	2 x 3/4"	1.1/4"	3/4"	3/4"
SH 2 11 D - Y	2 x 3/4"	1.1/4"	3/4"	3/4"
SH 2 13 D - Y	2 x 3/4"	1.1/4"	3/4"	3/4"
SH 3 13 D - Y	2 x 3/4"	1.1/4"	3/4"	3/4"
SH 4 16 D - Y	2 x 3/4"	1.1/4"	3/4"	3/4"
SH 3 18 D - Y	2 x 3/4"	1.1/4"	3/4"	3/4"
SH 5 19 F - Y	2 x 3/4"	1.1/4"	3/4"	3/4"
SH 4 24 F - Y	2 x 3/4"	1.1/4"	3/4"	3/4"
SH 5 25 Q - Y	2 x 3/4"	1.1/4"	3/4"	3/4"

Unità condensatrice Condensing unit Groupe de condensation Verflüssigungssatz	Collegamento Connection Connection Verbindung		Collegamento Connection Connection Verbindung	
	CW		MW	
	ingresso inlet entrée Eintritt	uscita outlet sortie Austritt	ingresso inlet entrée Eintritt	uscita outlet sortie Austritt
	W1 "FPT"	W2 "FPT"	W1 "FPT"	W2 "FPT"

SH 7 28 Q - Y	2 x 3/4"	1.1/4"	3/4"	3/4"
SH 5 33 Q - Y	2 x 3/4"	1.1/4"	3/4"	3/4"
SH 7 33 Q - Y	2 x 3/4"	1.1/4"	3/4"	3/4"
SH 7 39 S - Y	2 x 3/4"	1.1/4"	3/4"	3/4"
SH 10 39 S - Y	2 x 3/4"	1.1/4"	3/4"	3/4"
SH 10 51 S - Y	2 x 3/4"	1.1/4"	3/4"	3/4"
SH 15 51 S - Y	2 x 1"	1.1/2"	1"	1"
SH 20 56 S - Y	2 x 1"	1.1/2"	1"	1"
SH 15 71 V - Y	2 x 1"	1.1/2"	1"	1"
SH 20 84 V - Y	2 x 1"	1.1/2"	1"	1"
SH 30 84 V - Y	2 x 1"	1.1/2"	1"	1"

Capacità frigorifere

Refrigerating capacity

Puissances frigorifiques

Kälteleistungsdaten

Unità condensatrice Condensing unit Groupe de condensation Verflüssigungssatz	Condensazione Condensing Condensation Verflüssigungs- temperatur °C	R404A - R507A											
		Capacità frigorifere W			Refrigerating capacity W			Puissances frigorifiques W			Kälteleistungsdaten W		
		Temperatura di evaporazione °C			Evaporating temperature °C			Température d'évaporation °C			Verdampfungstemperatur °C		
		7.5	5	0	-5	-10	-15	-20	-25	-30	-35	-40	-45
SH 0.7 5 A - Y	40	5030	4200	3470	2850	2310	1840	1440	1100	800	560	340	
SH 1 6 A - Y	40	6100	5580	4650	3850	3160	2560	2040	1590	1220	890	620	380
SH 1.5 7 A - Y	40	7700	7040	5880	4860	4000	3230	2580	2010	1540	1130	790	
SH 1.5 9 B - Y	40		7630	6320	5200	4210	3360	2630	2020	1480	1040	640	
SH 2 11 D - Y	40	12540	11470	9570	7920	6520	5280	4220	3300	2530	1870	1310	
SH 2 13 D - Y	40			9640	7940	6450	5160	4060	3130	2320	1650	1050	
SH 3 13 D - Y	40	15080	13800	11520	9540	7860	6370	5100	3990	3070			
SH 4 16 D - Y	40	18050	16550	13880	11560	9580	7840	6340	5050	3970			
SH 3 18 D - Y	40			12610	10460	8560	6930	5520	4340	3320	2470	1700	
SH 5 19 F - Y	40	21770	19950	16730	13920	11540	9430	7620	6060	4750			
SH 4 24 F - Y	40			17320	14400	11810	9600	7680	6080	4690	3530	2490	
SH 5 25 Q - Y	40			18040	15010	12340	10040	8060	6400	4960	3770	2690	
SH 7 28 Q - Y	40	32000	29280	24450	20250	16680	13520	10810	8470	6510			
SH 5 33 Q - Y	40			19060	15590	12620	10060	7910	6050	4500	3100		
SH 7 33 Q - Y	40	35870	32880	27580	22970	19060	15590	12620	10060	7910			
SH 7 39 S - Y	40			27990	23270	19090	15510	12410	9820	7580	5710	4020	
SH 10 39 S - Y	40	43490	39870	33450	27870	23130	18940	15340	12230	9630			
SH 10 51 S - Y	40			30600	25040	20280	16160	12710	9720	7250	5000		
SH 15 51 S - Y	40	56420	51680	43260	35940	29720	24220	19500	15420	12010			
SH 20 56 S - Y	40	64620	59210	49600	41250	34150	27870	22490	17840	13940			
SH 15 71 V - Y	40			42560	34740	28040	22240	17390	13190	9700	6530		
SH 20 84 V - Y	40			50180	41180	33460	26790	21210	16370	12360	8720		
SH 30 84 V - Y	40	93800	86960	72050	59960	49680	40590	32800	26060	20420			

Unità condensatrice Condensing unit Groupe de condensation Verflüssigungssatz	Condensazione Condensing Condensation Verflüssigungs- temperatur °C	R407C											
		Capacità frigorifere W		Refrigerating capacity W		Puissances frigorifiques W			Kälteleistungsdaten W				
		Temperatura di evaporazione °C		Evaporating temperature °C		Température d'évaporation °C			Verdampfungstemperatur °C				
		12.5	7.5	5	0	-5	-10	-15	-20	-25			
SH 0.7 5 A - Y	40	6160	5100	4630	3790	3070	2450	1920	1480	1100			
SH 1 6 A - Y	40	6830	5660	5130	4200	3400	2710	2130	1640	1220			
SH 1.5 7 A - Y	40	8630	7150	6490	5310	4290	3430	2690	2070	1540			
SH 1.5 9 B - Y	40	A RICHIESTA		ON REQUEST		SUR DEMAND		AUF ANFRAGE					
SH 2 11 D - Y	40	14940	12350	11200	9140	7380	5870	4590	3500	2580			
SH 2 13 D - Y	40	A RICHIESTA		ON REQUEST		SUR DEMAND		AUF ANFRAGE					
SH 3 13 D - Y	40	16920	14010	12710	10390	8400	6700	5260	4030	2990			
SH 4 16 D - Y	40	20780	17190	15590	12730	10270	8170	6390	4870	3600			
SH 3 18 D - Y	40	A RICHIESTA		ON REQUEST		SUR DEMAND		AUF ANFRAGE					
SH 5 19 F - Y	40	24970	20670	18750	15320	12380	9870	7730	5920	4390			
SH 4 24 F - Y	40	A RICHIESTA		ON REQUEST		SUR DEMAND		AUF ANFRAGE					
SH 5 25 Q - Y	40	A RICHIESTA		ON REQUEST		SUR DEMAND		AUF ANFRAGE					
SH 7 28 Q - Y	40	35890	29710	26960	22050	17820	14220	11150	8550	6350			
SH 5 33 Q - Y	40	A RICHIESTA		ON REQUEST		SUR DEMAND		AUF ANFRAGE					
SH 7 33 Q - Y	40	42070	34890	31700	25980	21070	16880	13310	10290	7740			
SH 7 39 S - Y	40	A RICHIESTA		ON REQUEST		SUR DEMAND		AUF ANFRAGE					
SH 10 39 S - Y	40	51440	42560	38620	31550	25490	20310	15900	12160	9010			
SH 10 51 S - Y	40	A RICHIESTA		ON REQUEST		SUR DEMAND		AUF ANFRAGE					
SH 15 51 S - Y	40	64880	53700	48730	39830	32200	25670	20120	15410	11440			
SH 20 56 S - Y	40	73170	60720	55190	45280	36780	29520	23340	18090	13670			
SH 15 71 V - Y	40	A RICHIESTA		ON REQUEST		SUR DEMAND		AUF ANFRAGE					
SH 20 84 V - Y	40	A RICHIESTA		ON REQUEST		SUR DEMAND		AUF ANFRAGE					
SH 30 84 V - Y	40	107870	89360	81130	66400	53750	42950	33750	25960	19380			

Con raffreddamento della testa
With head cooling
Avec refroidissement de la coulisse
Mit Zylinderkopfkühlung

Capacità frigorifere

Refrigerating capacity

Puissances frigorifiques

Kälteleistungsdaten

Unità condensatrice Condensing unit Groupe de condensation Verflüssigungssatz	Condensazione Condensing Condensation Verflüssigungs- temperatur °C	R22												
		Capacità frigorifere W			Refrigerating capacity W				Puissances frigorifiques W				Kälteleistungsdaten W	
		Temperatura di evaporazione °C			Evaporating temperature °C				Température d'évaporation °C				Verdampfungstemperatur °C	
		12.5	7.5	5	0	-5	-10	-15	-20	-25	-30	-35	-40	-45
SH 0.7 5 A - Y	40	5960	4970	4520	3720	3030	2430	1920	1480	1120	820	580	400	
SH 1 6 A - Y	40	6610	5510	5010	4130	3360	2710	2130	1650	1250	920	650	440	
SH 1.5 7 A - Y	40	8470	7090	6470	5350	4390	3560	2840	2230	1710	1290	950		
SH 1.5 9 B - Y	40			8740	7220	5910	4790	3850	3050	2370	1800	1320	940	630
SH 2 11 D - Y	40	14450	12070	11010	9150	7540	6130	4900	3850	2930	2170	1530		
SH 2 13 D - Y	40			13170	11000	9090	7430	5980	4720	3640	2730	1970	1330	820
SH 3 13 D - Y	40	17250	14420	13160	10900	8950	7260	5800	4540	3470	2570			
SH 4 16 D - Y	40	20420	17110	15620	13060	10810	8850	7150	5670	4400	3320			
SH 3 18 D - Y	40				12130	9920	8010	6350	4930	3720	2710	1860	1170	
SH 5 19 F - Y	40	25020	20840	18980	15620	12740	10270	8150	6360	4870	3630			
SH 4 24 F - Y	40				15900	12920	10350	8160	6380	4860	3570	2490	1580	
SH 5 25 Q - Y	40		26260	23880	19750	16180	13090	10440	8170	6250	4640	3310	2220	1360
SH 7 28 Q - Y	40	36590	30600	27910	23130	18980	15390	12290	9640	7360	5460			
SH 5 33 Q - Y	40				21420	17550	14150	11180	8630	6460	4650	3180	1990	
SH 7 33 Q - Y	40	40460	34060	31190	26000	21510	17770	14520	11710	9290	7240			
SH 7 39 S - Y	40				26500	21390	17030	13320	10200	7620	5500	3800	2470	
SH 10 39 S - Y	40	51050	42420	38560	31620	25640	20530	16160	12480	9410	6880			
SH 10 51 S - Y	40				33770	27100	21460	16470	12820	9610	7000	4920	3350	
SH 15 51 S - Y	40	65490	54570	49680	40620	32870	26280	20700	16010	12110	8920			
SH 20 56 S - Y	40	72690	60570	55140	46020	38010	31010	24910	19660	15170	11390			
SH 15 71 V - Y	40				47720	38390	30580	24080	18720	14330	10780	7920	5840	
SH 20 84 V - Y	40				56600	45430	36090	28320	21920	16700	12470	9080	6620	
SH 30 84 V - Y	40	110110	92940	85220	69560	56350	45250	35960	28240	21870	16660			

FTEC09-04

Unità condensatrice Condensing unit Groupe de condensation Verflüssigungssatz	Condensazione Condensing Condensation Verflüssigungs- temperatur °C	R134a												
		Capacità frigorifere W			Refrigerating capacity W			Puissances frigorifiques W			Kälteleistungsdaten W			
		Temperatura di evaporazione °C			Evaporating temperature °C			Température d'évaporation °C			Verdampfungstemperatur °C			
		12.5	7.5	5	0	-5	-10	-15	-20					
SH 0.7 5 A - Y	40	4030	3330	3020	2460	1980	1570	1230	930					
SH 1 6 A - Y	40	4470	3690	3350	2730	2200	1740	1360	1030					
SH 1.5 7 A - Y	40	5810	4800	4350	3550	2850	2270	1770	1340					
SH 1.5 9 B - Y	40	7630	6290	5700	4630	3720	2940	2280	1720					
SH 2 11 D - Y	40	9560	7870	7120	5780	4630	3650	2810	2110					
SH 2 13 D - Y	40	11330	9330	8450	6860	5500	4330	3350	2520					
SH 3 13 D - Y	40	11300	9310	8420	6830	5460	4300	3320	2480					
SH 4 16 D - Y	40	13680	11260	10190	8260	6610	5200	4010	3000					
SH 3 18 D - Y	40	16140	13300	12030	9770	7830	6170	4770	3580					
SH 5 19 F - Y	40	16390	13570	12320	10070	8150	6510	5120	3940					
SH 4 24 F - Y	40	20150	16680	15130	12370	10000	7970	6260	4810					
SH 5 25 Q - Y	40	21630	17920	16270	13310	10770	8610	6780	5230					
SH 7 28 Q - Y	40	23970	19740	17860	14480	11590	9120	7030	5260					
SH 5 33 Q - Y	40	29410	24230	21920	17790	14260	11240	8690	6520					
SH 7 33 Q - Y	40	29410	24230	21920	17790	14260	11240	8690	6520					
SH 7 39 S - Y	40	33770	27980	25410	20790	16840	13470	10620	8200					
SH 10 39 S - Y	40	33010	27360	24840	20340	16480	13180	10390	8030					
SH 10 51 S - Y	40	43350	35890	32560	26600	21500	17150	13460	10340					
SH 15 51 S - Y	40	42460	35130	31870	26030	21030	16760	13140	10070					
SH 20 56 S - Y	40	48680	40300	36570	29880	24160	19280	15140	11640					
SH 15 71 V - Y	40	61510	50920	46200	37760	30530	24360	19130	14700					
SH 20 84 V - Y	40	71020	58820	53370	43640	35300	28190	22160	17050					
SH 30 84 V - Y	40	70110	58030	52640	43010	34760	27720	21740	16690					

Con raffreddamento della testa
With head cooling
Avec refroidissement de la coulasse
Mit Zylinderkopfkühlung

Con iniezione di liquido e raffreddamento della testa
With liquid injection and head cooling
Avec injection de liquide et refroidissement de la coulasse
Mit Flüssigkeitseinspritzung und Zylinderkopfkühlung

Capacità frigorifere

Refrigerating capacity

Puissances frigorifiques

Kälteleistungsdaten

Unità condensatrice Condensing unit Groupe de condensation Verflüssigungssatz	Condensazione Condensing Condensation Verflüssigungs- temperatur °C	R404A - R507A												
		Capacità frigorifere W			Refrigerating capacity W			Puissances frigorifiques W			Kälteleistungsdaten W			
		Temperatura di evaporazione °C			Evaporating temperature °C			Température d'évaporation °C			Verdampfungstemperatur °C			
		7.5	5	0	-5	-10	-15	-20	-25	-30	-35	-40	-45	
SH 0.7 5 A - Y	40		6040	5040	4160	3420	2770	2210	1730	1320	960	670	410	
SH 1 6 A - Y	40		7320	6700	5580	4620	3790	3070	2450	1910	1460	1070	740	460
SH 1.5 7 A - Y	40		9240	8450	7060	5830	4800	3880	3100	2410	1850	1360	950	
SH 1.5 9 B - Y	40			9160	7580	6240	5050	4030	3160	2420	1780	1250	770	
SH 2 11 D - Y	40		15050	13760	11480	9500	7820	6340	5060	3960	3040	2240	1570	
SH 2 13 D - Y	40				11570	9530	7740	6190	4870	3760	2780	1980	1260	
SH 3 13 D - Y	40		18100	16560	13820	11450	9430	7640	6120	4790	3680			
SH 4 16 D - Y	40		21660	19860	16660	13870	11500	9410	7610	6060	4760			
SH 3 18 D - Y	40				15130	12550	10270	8320	6620	5210	3980	2960	2040	
SH 5 19 F - Y	40		26120	23940	20080	16700	13850	11320	9140	7270	5700			
SH 4 24 F - Y	40				20780	17280	14170	11520	9220	7300	5630	4240	2990	
SH 5 25 Q - Y	40				21650	18010	14810	12050	9670	7680	5950	4520	3230	
SH 7 28 Q - Y	40		38400	35140	29340	24300	20020	16220	12970	10160	7810			
SH 5 33 Q - Y	40				22870	18710	15140	12070	9490	7260	5400	3720		
SH 7 33 Q - Y	40		43040	39460	33100	27560	22870	18710	15140	12070	9490			
SH 7 39 S - Y	40				33590	27920	22910	18610	14890	11780	9100	6850	4820	
SH 10 39 S - Y	40		52190	47840	40140	33440	27760	22730	18410	14680	11560			
SH 10 51 S - Y	40				36720	30050	24340	19390	15250	11660	8700	6000		
SH 15 51 S - Y	40		67700	62020	51910	43130	35660	29060	23400	18500	14410			
SH 20 56 S - Y	40		77540	71050	59520	49500	40980	33440	26990	21410	16730			
SH 15 71 V - Y	40				51070	41690	33650	26690	20870	15830	11640	7840		
SH 20 84 V - Y	40				60220	49420	40150	32150	25450	19640	14830	10460		
SH 30 84 V - Y	40		112560	104350	86460	71950	59620	48710	39360	31270	24500			

Unità condensatrice Condensing unit Groupe de condensation Verflüssigungssatz	Condensazione Condensing Condensation Verflüssigungs- temperatur °C	R407C											
		Capacità frigorifere W			Refrigerating capacity W			Puissances frigorifiques W			Kälteleistungsdaten W		
		Temperatura di evaporazione °C			Evaporating temperature °C			Température d'évaporation °C			Verdampfungstemperatur °C		
		12.5	7.5	5	0	-5	-10	-15	-20	-25			
SH 0.7 5 A - Y	40		6120	5560	4550	3680	2940	2300	1780	1320			
SH 1 6 A - Y	40		8200	6790	6160	5040	4080	3250	2560	1970	1460		
SH 1.5 7 A - Y	40		10360	8580	7790	6370	5150	4120	3230	2480	1850		
SH 1.5 9 B - Y	40		A RICHIESTA	ON REQUEST	ON REQUEST	SUR DEMAND	AUF ANFRAGE						
SH 2 11 D - Y	40		17930	14820	13440	10970	8860	7040	5510	4200	3100		
SH 2 13 D - Y	40		A RICHIESTA	ON REQUEST	SUR DEMAND	AUF ANFRAGE							
SH 3 13 D - Y	40		20300	16810	15250	12470	10080	8040	6310	4840	3590		
SH 4 16 D - Y	40		24940	20630	18710	15280	12320	9800	7670	5840	4320		
SH 3 18 D - Y	40		A RICHIESTA	ON REQUEST	SUR DEMAND	AUF ANFRAGE							
SH 5 19 F - Y	40		29960	24800	22500	18380	14860	11840	9280	7100	5270		
SH 4 24 F - Y	40		A RICHIESTA	ON REQUEST	SUR DEMAND	AUF ANFRAGE							
SH 5 25 Q - Y	40		A RICHIESTA	ON REQUEST	SUR DEMAND	AUF ANFRAGE							
SH 7 28 Q - Y	40		43070	35650	32350	26460	21380	17060	13380	10260	7620		
SH 5 33 Q - Y	40		A RICHIESTA	ON REQUEST	SUR DEMAND	AUF ANFRAGE							
SH 7 33 Q - Y	40		50480	41870	38040	31180	25280	20260	15970	12350	9290		
SH 7 39 S - Y	40		A RICHIESTA	ON REQUEST	SUR DEMAND	AUF ANFRAGE							
SH 10 39 S - Y	40		61730	51070	46340	37860	30590	24370	19080	14590	10810		
SH 10 51 S - Y	40		A RICHIESTA	ON REQUEST	SUR DEMAND	AUF ANFRAGE							
SH 15 51 S - Y	40		77860	64440	58480	47800	38640	30800	24140	18490	13730		
SH 20 56 S - Y	40		87800	72860	66230	54340	44140	35420	28010	21710	16400		
SH 15 71 V - Y	40		A RICHIESTA	ON REQUEST	SUR DEMAND	AUF ANFRAGE							
SH 20 84 V - Y	40		A RICHIESTA	ON REQUEST	SUR DEMAND	AUF ANFRAGE							
SH 30 84 V - Y	40		129440	107230	97360	79680	64500	51540	40500	31150	23260		

Con raffreddamento della testa
With head cooling
Avec refroidissement de la coulasse
Mit Zylinderkopfkühlung

Capacità frigorifere

Refrigerating capacity

Puissances frigorifiques

Kälteleistungsdaten

Unità condensatrice Condensing unit Groupe de condensation Verflüssigungssatz	Condensazione Condensing Condensation Verflüssigungs- temperatur °C	R22												
		Capacità frigorifere W			Refrigerating capacity W			Puissances frigorifiques W			Kälteleistungsdaten W			
		Temperatura di evaporazione °C			Evaporating temperature °C			Température d'évaporation °C			Verdampfungstemperatur °C			
		12.5	7.5	5	0	-5	-10	-15	-20	-25	-30	-35	-40	-45
SH 0.7 5 A - Y	40	7150	5960	5420	4460	3640	2920	2300	1780	1340	980	700	480	
SH 1 6 A - Y	40	7930	6610	6010	4960	4030	3250	2560	1980	1500	1100	780	530	
SH 1.5 7 A - Y	40	10160	8510	7760	6420	5270	4270	3410	2680	2050	1550	1140		
SH 1.5 9 B - Y	40			10490	8660	7090	5750	4620	3660	2840	2160	1580	1130	760
SH 2 11 D - Y	40	17340	14480	13210	10980	9050	7360	5880	4620	3520	2600	1840		
SH 2 13 D - Y	40			15800	13200	10910	8920	7180	5660	4370	3280	2360	1600	980
SH 3 13 D - Y	40	20700	17300	15790	13080	10740	8710	6960	5450	4160	3080			
SH 4 16 D - Y	40	24500	20530	18740	15670	12970	10620	8580	6800	5280	3980			
SH 3 18 D - Y	40				14560	11900	9610	7620	5920	4460	3250	2230	1400	
SH 5 19 F - Y	40	30020	25010	22780	18740	15290	12320	9780	7630	5840	4360			
SH 4 24 F - Y	40				19080	15500	12420	9790	7660	5830	4280	2990	1900	
SH 5 25 Q - Y	40		31510	28660	23700	19420	15710	12530	9800	7500	5570	3970	2660	1630
SH 7 28 Q - Y	40	43910	36720	33490	27760	22780	18470	14750	11570	8830	6550			
SH 5 33 Q - Y	40				25700	21060	16980	13420	10360	7750	5580	3820	2390	
SH 7 33 Q - Y	40	48550	40870	37430	31200	25810	21320	17420	14050	11150	8690			
SH 7 39 S - Y	40				31800	25670	20440	15980	12240	9140	6600	4560	2960	
SH 10 39 S - Y	40	61260	50900	46270	37940	30770	24640	19390	14980	11290	8260			
SH 10 51 S - Y	40				40520	32520	25750	19760	15380	11530	8400	5900	4020	
SH 15 51 S - Y	40	78590	65480	59620	48740	39440	31540	24840	19210	14530	10700			
SH 20 56 S - Y	40	87230	72680	66170	55220	45610	37210	29890	23590	18200	13670			
SH 15 71 V - Y	40				57260	46070	36700	28900	22460	17200	12940	9500	7010	
SH 20 84 V - Y	40				67920	54520	43310	33980	26300	20040	14960	10900	7940	
SH 30 84 V - Y	40	132130	111530	102260	83470	67620	54300	43150	33890	26240	19990			

FTEC09-04

Unità condensatrice Condensing unit Groupe de condensation Verflüssigungssatz	Condensazione Condensing Condensation Verflüssigungs- temperatur °C	R134a									
		Capacità frigorifere W			Refrigerating capacity W			Puissances frigorifiques W		Kälteleistungsdaten W	
		Temperatura di evaporazione °C			Evaporating temperature °C			Température d'évaporation °C		Verdampfungstemperatur °C	
		12.5	7.5	5	0	-5	-10	-15	-20		
SH 0.7 5 A - Y	40	4840	4000	3620	2950	2380	1880	1480	1120		
SH 1 6 A - Y	40	5360	4430	4020	3280	2640	2090	1630	1240		
SH 1.5 7 A - Y	40	6970	5760	5220	4260	3420	2720	2120	1610		
SH 1.5 9 B - Y	40	9160	7550	6840	5560	4460	3530	2740	2060		
SH 2 11 D - Y	40	11470	9440	8540	6940	5560	4380	3370	2530		
SH 2 13 D - Y	40	13600	11200	10140	8230	6600	5200	4020	3020		
SH 3 13 D - Y	40	13560	11170	10100	8200	6550	5160	3980	2980		
SH 4 16 D - Y	40	16420	13510	12230	9910	7930	6240	4810	3600		
SH 3 18 D - Y	40	19370	15960	14440	11720	9400	7400	5720	4300		
SH 5 19 F - Y	40	19670	16280	14780	12080	9780	7810	6140	4730		
SH 4 24 F - Y	40	24180	20020	18160	14840	12000	9560	7510	5770		
SH 5 25 Q - Y	40	25960	21500	19520	15970	12920	10330	8140	6280		
SH 7 28 Q - Y	40	28760	23690	21430	17380	13910	10940	8440	6310		
SH 5 33 Q - Y	40	35290	29080	26300	21350	17110	13490	10430	7820		
SH 7 33 Q - Y	40	35290	29080	26300	21350	17110	13490	10430	7820		
SH 7 39 S - Y	40	40520	33580	30490	24950	20210	16160	12740	9840		
SH 10 39 S - Y	40	39610	32830	29810	24410	19780	15820	12470	9640		
SH 10 51 S - Y	40	52020	43070	39070	31920	25800	20580	16150	12410		
SH 15 51 S - Y	40	50950	42160	38240	31240	25240	20110	15770	12080		
SH 20 56 S - Y	40	58420	48360	43880	35860	28990	23140	18170	13970		
SH 15 71 V - Y	40	73810	61100	55440	45310	36640	29230	22960	17640		
SH 20 84 V - Y	40	85220	70580	64040	52370	42360	33830	26590	20460		
SH 30 84 V - Y	40	84130	69640	63170	51610	41710	33260	26090	20030		

Con raffreddamento della testa
With head cooling
Avec refroidissement de la coulasse
Mit Zylinderkopfkühlung

Con iniezione di liquido e raffreddamento della testa
With liquid injection and head cooling
Avec injection de liquide et refroidissement de la coulasse
Mit Flüssigkeitseinspritzung und Zylinderkopfkühlung

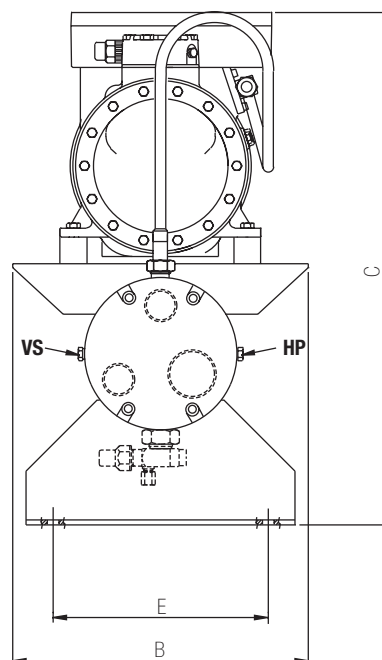
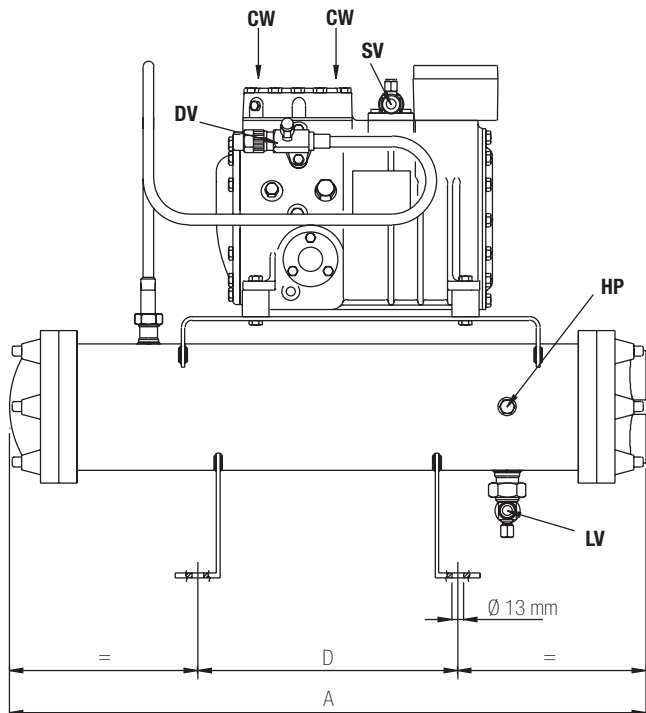

Disegno Drawing **1**
Plan Zeichnung

FTEC09-04

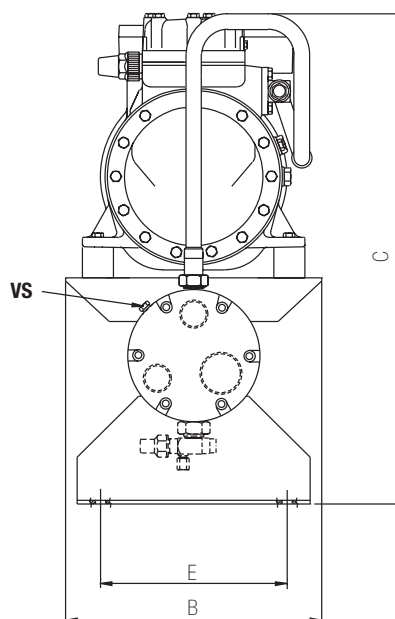
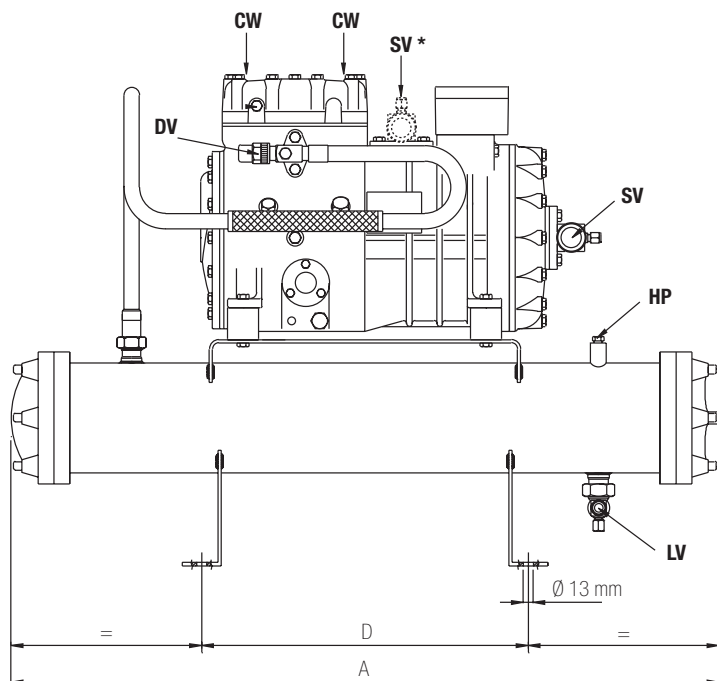

* posizione del rubinetto di aspirazione per il modello SH 4 24 FY
suction valve location for model SH 4 24 FY
position de la vanne d'aspiration pour le modèle SH 4 24 FY
Stellung des Saugventiles für das Modell SH 4 24 FY

Disegno Drawing **2**
Plan Zeichnung

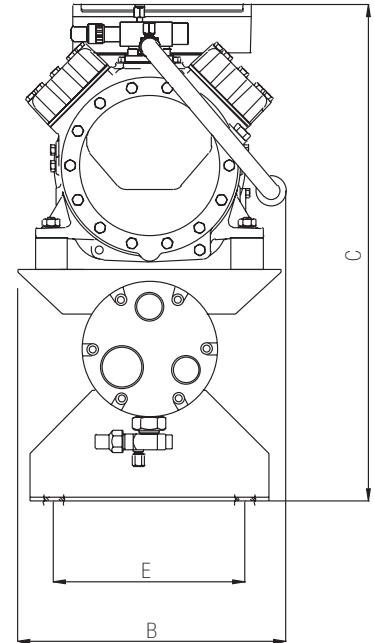
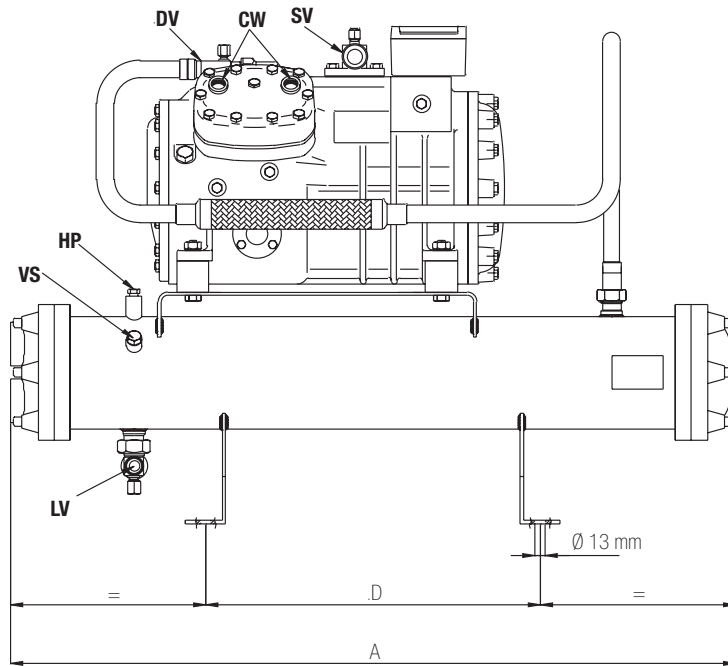

Disegno Drawing **3**
Plan Zeichnung

FTEC09-04

Unità condensatrice Condensing unit Groupe de condensation Verflüssigungssatz	Rubinetto aspirazione Suction valve Vanne d'aspiration Saugventil		Rubinetto del liquido Liquid valve Vanne du liquide Flüssigkeitsventil		Lunghezza Length Longueur Länge	Larghezza Width Largeur Breite	Altezza Height Hauteur Höhe	Interassi di fissaggio Base mounting Trous fixation Befestigungslöcher		Peso netto Net weight Poids net Netto Gewicht	Peso lordo Gross weight Poids brut Brutto Gewicht	Disegno Drawing Plan Zeichnung
	Ø "	Ø mm	Ø "	Ø mm				D mm	E mm			
SH 0.7 5 A - Y	5/8	15.8	1/2	12.7	710	330	571	290	240	62	67	1
SH 1 6 A - Y	5/8	15.8	1/2	12.7	710	330	571	290	240	62	67	1
SH 1.5 7 A - Y	5/8	15.8	1/2	12.7	710	330	571	290	240	62	67	1
SH 1.5 9 B - Y	5/8	15.8	1/2	12.7	710	330	588	290	240	62	71	1
SH 2 11 D - Y	7/8	22.2	5/8	15.8	910	330	605	420	240	87	95	1
SH 2 13 D - Y	7/8	22.2	1/2	12.7	710	330	605	290	240	72	77	1
SH 3 13 D - Y	1 1/8	28.6	5/8	15.8	910	330	623	420	240	91	99	1
SH 4 16 D - Y	1 1/8	28.6	5/8	15.8	910	330	623	420	240	93	101	1
SH 3 18 D - Y	1 1/8	28.6	5/8	15.8	910	330	623	420	240	91	99	1
SH 5 19 F - Y	1 1/8	28.6	3/4	19.0	910	330	630	420	240	121	129	2
SH 4 24 F - Y	1 1/8	28.6	5/8	15.8	910	330	630	420	240	116	124	2
SH 5 25 Q - Y	1 1/8	28.6	5/8	15.8	910	327	624	420	240	121	129	3
SH 7 28 Q - Y	1 3/8	35.0	3/4	19.0	910	327	624	420	240	124	132	3
SH 5 33 Q - Y	1 3/8	35.0	3/4	19.0	910	327	624	420	240	125	129	3
SH 7 33 Q - Y	1 3/8	35.0	7/8	22.0	910	327	653	420	240	127	131	3

CW	attacco per acqua raffreddamento testata	connection for water head cooling	raccord pour eau refroidissement culasse	Anschluß für wassergekühlten Kopf
DV	rubinetto di compressione	discharge valve	vanne de refoulement	Druckventil
LV	rubinetto del liquido	liquid valve	vanne du liquide	Flüssigkeitsventil
HP	tappo di alta pressione condensatore	condenser high pressure plug	condenseur bouchon haute pression	Verflüssiger Stopfen Druckseite
SV	rubinetto di aspirazione	suction valve	vanne d'aspiration	Saugventil
VS	tappo per valvola di sicurezza	safety valve plug	bouchon pour vanne de sûreté	Stopfen Sicherheitsventil

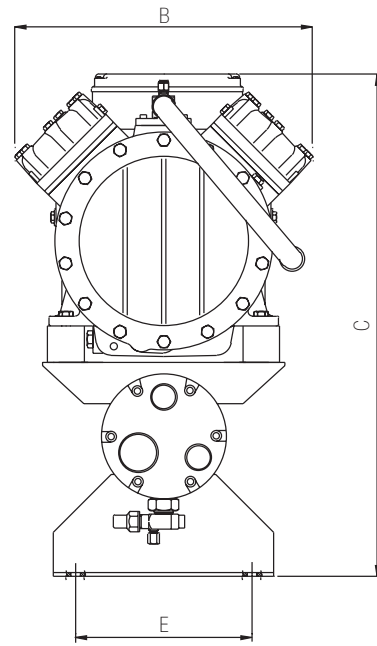
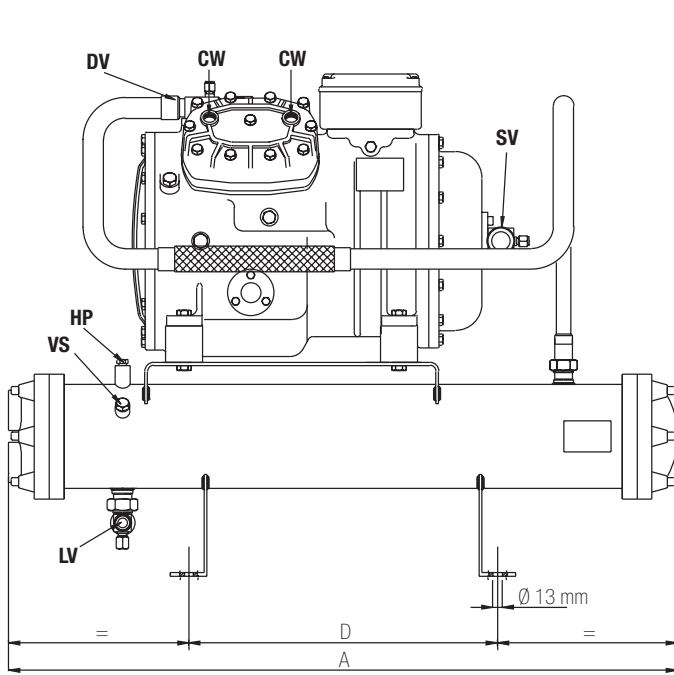

Disegno Drawing 4
Plan Zeichnung

FTEC09-04

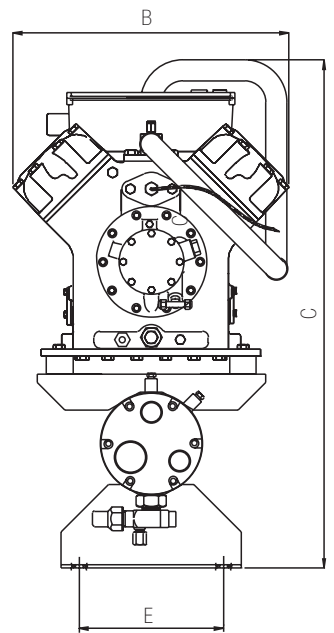
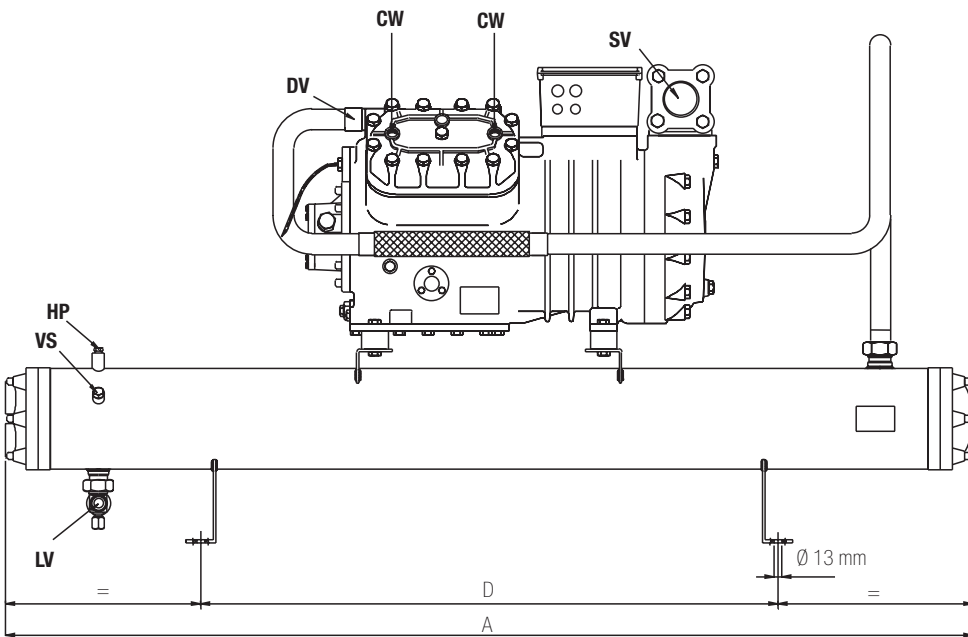

Disegno Drawing 5
Plan Zeichnung

Dimensioni di ingombro

Dimensional drawing

Plans cotés

Mass Zeichnungen

Unità condensatrice Condensing unit Groupe de condensation Verflüssigungssatz	Rubinetto aspirazione Suction valve Vanne d'aspiration Saugventil		Rubinetto del liquido Liquid valve Vanne du liquide Flüssigkeitsventil		Lunghezza Length Longueur Länge	Larghezza Width Largeur Breite	Altezza Height Hauteur Höhe	Interassi di fissaggio Base mounting Trous fixation Befestigungslöcher		Peso netto Net weight Poids net Netto Gewicht	Peso lordo Gross weight Poids brut Brutto Gewicht	Disegno Drawing Plan Zeichnung
	Ø "	Ø mm	Ø "	Ø mm				D mm	E mm			
	kg	kg										
SH 7 39 S - Y	1 3/8	35.0	3/4	19.0	910	405	684	420	240	163	178	4
SH 10 39 S - Y	1 3/8	35.0	7/8	22.2	910	405	684	420	240	168	183	4
SH 10 51 S - Y	1 3/8	35.0	7/8	22.2	910	405	684	420	240	168	183	4
SH 15 51 S - Y	1 5/8	42.0	7/8	22.2	1610	405	690	960	240	195	220	4
SH 20 56 S - Y	1 5/8	42.0	7/8	22.2	1610	405	690	960	240	201	226	4
SH 15 71 V - Y	1 5/8	42.0	1 1/8	28.6	1610	465	795	960	240	240	265	5
SH 20 84 V - Y	1 5/8	42.0	1 1/8	28.6	1610	465	795	960	240	250	275	5
SH 30 84 V - Y	1 5/8	42.0	1 1/8	28.6	1610	465	845	960	240	268	293	5

CW	attacco per acqua raffreddamento testata	connection for water head cooling	raccord pour eau refroidissement culasse	Anschluß für wassergekühlten Kopf
DV	rubinetto di compressione	discharge valve	vanne de refolement	Druckventil
LV	rubinetto del liquido	liquid valve	vanne du liquide	Flüssigkeitsventil
HP	tappo di alta pressione condensatore	condenser high pressure plug	condenseur bouchon haute pression	Verflüssiger Stopfen Druckseite
SV	rubinetto di aspirazione	suction valve	vanne d'aspiration	Saugventil
VS	tappo per valvola di sicurezza	safety valve plug	bouchon pour vanne de sûreté	Stopfen Sicherheitsventil

Collegamenti lato acqua

Water side connections

Raccord côté eau

Anschlüsse wasserseitig

CW

Collegamento per alimentazione con acqua di torre evaporativa
Connection for cooling tower water supply
Connection pour prise d'eau de tour de refroidissement
Verbindung zur Versorgung mit Kühlturmwasser

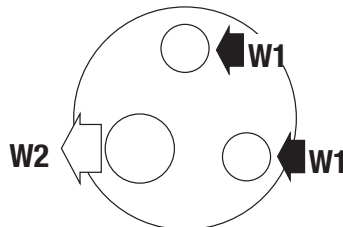

MW

Collegamento per alimentazione con acqua di pozzo
Connection for mains water supply
Connection pour prise d'eau de ville
Verbindung zur Versorgung mit Stadtwasser

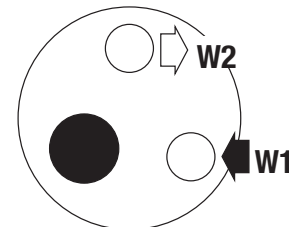

Unità condensatrice Condensing unit Groupe de condensation Verflüssigungssatz	Collegamento Connection Connection Verbindung		Collegamento Connection Connection Verbindung		Unità condensatrice Condensing unit Groupe de condensation Verflüssigungssatz	Collegamento Connection Connection Verbindung		Collegamento Connection Connection Verbindung	
	CW		MW			CW		MW	
	ingresso inlet entrée Eintritt	uscita outlet sortie Austritt	ingresso inlet entrée Eintritt	uscita outlet sortie Austritt		ingresso inlet entrée Eintritt	uscita outlet sortie Austritt	ingresso inlet entrée Eintritt	uscita outlet sortie Austritt
	W1 "FPT"	W2 "FPT"	W1 "FPT"	W2 "FPT"		W1 "FPT"	W2 "FPT"	W1 "FPT"	W2 "FPT"
SH 0.7 5 A - Y	2 x 3/4"	1.1/4"	3/4"	3/4"	SH 7 28 Q - Y	2 x 3/4"	1.1/4"	3/4"	3/4"
SH 1 6 A - Y	2 x 3/4"	1.1/4"	3/4"	3/4"	SH 5 33 Q - Y	2 x 3/4"	1.1/4"	3/4"	3/4"
SH 1.5 7 A - Y	2 x 3/4"	1.1/4"	3/4"	3/4"	SH 7 33 Q - Y	2 x 3/4"	1.1/4"	3/4"	3/4"
SH 1.5 9 B - Y	2 x 3/4"	1.1/4"	3/4"	3/4"	SH 7 39 S - Y	2 x 3/4"	1.1/4"	3/4"	3/4"
SH 2 11 D - Y	2 x 3/4"	1.1/4"	3/4"	3/4"	SH 10 39 S - Y	2 x 3/4"	1.1/4"	3/4"	3/4"
SH 2 13 D - Y	2 x 3/4"	1.1/4"	3/4"	3/4"	SH 10 51 S - Y	2 x 3/4"	1.1/4"	3/4"	3/4"
SH 3 13 D - Y	2 x 3/4"	1.1/4"	3/4"	3/4"	SH 15 51 S - Y	2 x 1"	1.1/2"	1"	1"
SH 4 16 D - Y	2 x 3/4"	1.1/4"	3/4"	3/4"	SH 20 56 S - Y	2 x 1"	1.1/2"	1"	1"
SH 3 18 D - Y	2 x 3/4"	1.1/4"	3/4"	3/4"	SH 15 71 V - Y	2 x 1"	1.1/2"	1"	1"
SH 5 19 F - Y	2 x 3/4"	1.1/4"	3/4"	3/4"	SH 20 84 V - Y	2 x 1"	1.1/2"	1"	1"
SH 4 24 F - Y	2 x 3/4"	1.1/4"	3/4"	3/4"	SH 30 84 V - Y	2 x 1"	1.1/2"	1"	1"
SH 5 25 Q - Y	2 x 3/4"	1.1/4"	3/4"	3/4"					

Unità di compressione per condensazione remota Compressor/receiver groups for remote condenser Groupes de compression pour condenseur séparé Verdichtersätze mit Sammler

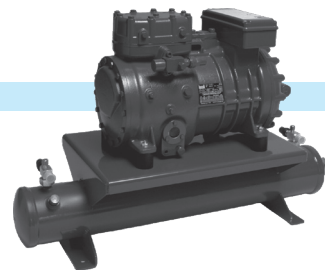

Le unità di compressione **CR** sono essenzialmente composte da compressore semiermetico, ricevitore di liquido con attacco per valvola di sicurezza, rubinetti, basamento e, nei modelli dove previsto, pressostato differenziale olio di tipo elettronico. Possono essere fornite complete di resistenza per il riscaldamento dell'olio nel carter, dispositivo per il controllo della capacità, dispositivo per la partenza a vuoto.

CR compressor/receiver group are essentially composed of semi-hermetic compressor, liquid receiver with safety valve connection, service valves, base frame and, where foreseen, electronic oil pressure switch. They can be supplied with oil crankcase heater, capacity control device, unloaded start device.

Les groupes de compression **CR** se composent de compresseur semi-hermétique, réservoir de liquide avec connexion pour soupape de sûreté, vannes d'isolement, châssis et, sur certains modèles, d'un pressostat différentiel d'huile de type électronique. Ils peuvent être fournis d'une résistance de carter pour le chauffage de l'huile, d'un contrôle de capacité et d'un démarrage à vide.

Die Verdichtersätze der Baureihe **CR** beinhalten halbhermetische Verdichter, Sammler mit Anschluß für Sicherheitsventil, Ventile, Grundrahmen und ein Öldifferenzdruckschalter. Als Zubehör ist erhältlich: Kurbelwannenheizung, bei bestimmten Typen ist weiterhin eine Anlaufentlastung sowie Leistungsregelung lieferbar.

Dati tecnici

Technical data

Données techniques

Technische Daten

Gruppo di compressione Compressor/receiver Groupe de compression Verdichtersätze mit Sammler	Compressore Compressor Compresseur Verdichter	Capacità Capacity Capacité Inhalt	Ricevitore di liquido Liquid receiver Réservoir de liquide Flüssigkeitssammler				Approvazioni Approvals Homologations Geprüft	Peso Weights Poids Gewicht		
			Modello Model Modèle Modell	Carica massima di refrigerante Maximum refrigerant charge Charge maximum de réfrigérant Maximale Kältemittelfüllung				netto net Netto	lordo gross brut Brutto	
					R404A/R507 kg	R407C kg				R22 kg
CR 2 11 D - Y	D 2 11 - Y	8.0	6.4	7.1	7.5	7.5	-	51	59	
CR 2 13 D - Y	D 2 13 - Y	8.0	6.4	7.1	7.5	7.5	-	51	56	
CR 3 13 D - Y	D 3 13 - Y	8.0	6.4	7.1	7.5	7.5	-	55	63	
CR 4 16 D - Y	D 4 16 - Y	8.0	6.4	7.1	7.5	7.5	-	57	65	
CR 3 18 D - Y	D 3 18 - Y	8.0	6.4	7.1	7.5	7.5	-	55	63	
CR 5 19 F - Y	F 5 19 - Y	19.0	15.2	16.8	17.7	17.9	-	90	98	
CR 4 24 F - Y	F 4 24 - Y	12.0	9.6	10.6	11.2	11.3	-	83	91	
CR 5 25 Q - Y	Q 5 25 - Y	12.0	9.6	10.6	11.2	11.3	-	88	96	
CR 5 33 Q - Y	Q 5 33 - Y	19.0	15.2	16.8	17.7	17.9	-	103	118	
CR 7 33 Q - Y	Q 7 33 - Y	24.0	19.2	21.2	22.4	22.6	-	110	125	
CR 7 39 S - Y	S 7 39 - Y	19.0	15.2	16.8	17.7	17.9	-	131	146	
CR 10 39 S - Y	S 10 39 - Y	24.0	19.2	21.2	22.4	22.6	-	139	154	
CR 10 51 S - Y	S 10 51 - Y	24.0	19.2	21.2	22.4	22.6	-	139	154	
CR 15 51 S - Y	S 15 51 - Y	24.0	19.2	21.2	22.4	22.6	-	145	160	
CR 20 56 S - Y	S 20 56 - Y	24.0	19.2	21.2	22.4	22.6	-	151	166	
CR 15 71 V - Y	V 15 71 - Y	30.0	24.4	26.5	28.0	28.3	TÜV	195	210	
CR 20 84 V - Y	V 20 84 - Y	30.0	24.4	26.5	28.0	28.3	TÜV	195	210	
CR 30 84 V - Y	V 30 84 - Y	40.0	32.1	35.3	37.3	37.7	TÜV	220	235	
CR 25 106 Z - Y	Z 25 106 - Y	40.0	32.1	35.3	37.3	37.7	TÜV	253	283	
CR 35 106 Z - Y	Z 35 106 - Y	60.0	48.1	52.9	55.9	56.6	TÜV	267	297	
CR 30 126 Z - Y	Z 30 126 - Y	40.0	32.1	35.3	37.3	37.7	TÜV	262	292	
CR 40 126 Z - Y	Z 40 126 - Y	60.0	48.1	52.9	55.9	56.6	TÜV	284	314	
CR 40 154 Z - Y	Z 40 154 - Y	40.0	32.1	35.3	37.3	37.7	TÜV	273	303	

① ricevitore riempito al 80% con refrigerante liquido a +32°C
receiver filled to 80% with liquid refrigerant at +32°C
à +32°C température de liquide et 80% contenance du réservoir
bei +32°C Flüssigkeitstemperatur und 80% Behälterinhalt

Dimensioni di ingombro

Dimensional drawing

Plans cotés

Mass Zeichnungen

Gruppo di compressione Compressor/receiver Groupe de compression Verbundanlage	Compressore Compressor Compresseur Verdichter				Ricevitore di liquido Liquid receiver Réservoir de liquide Flüssigkeitssammler			Unità di compressione Compressor/receiver group Groupe de compression Verbundanlage					Disegno Drawing Plan Zeichn.
	Rubinetto aspirazione Suction valve Vanne d'aspiration Saugventil		Rubinetto compressione Discharge valve Vanne refoulement Druckventil		Ingresso Inlet Entrée Eintritt	Uscita Outlet Sortie Austritt		Lunghezza Length Longueur Länge	Larghezza Width Largeur Breite	Altezza Height Hauteur Höhe	Interassi di fissaggio Base mounting Trous fixation Befestigungslöcher		
	Ø "	Ø mm	Ø "	Ø mm	Ø UNF	Ø "	Ø mm	A mm	B mm	C mm	D mm	E mm	
CR 2 11 D - Y	7/8	22.2	5/8	15.8	1"-14	5/8	15.8	670	330	565	400	180	1
CR 2 13 D - Y	7/8	22.2	5/8	15.8	1"-14	1/2	12.7	670	330	565	400	180	1
CR 3 13 D - Y	1 1/8	28.6	5/8	15.8	1"-14	5/8	15.8	670	330	565	400	180	1
CR 4 16 D - Y	1 1/8	28.6	3/4	19.0	1"-14	5/8	15.8	670	330	565	400	180	1
CR 3 18 D - Y	1 1/8	28.6	5/8	15.8	1"-14	5/8	15.8	670	330	565	400	180	1
CR 5 19 F - Y	1 1/8	28.6	3/4	19.0	1 1/4"-12	3/4	19.0	1000	360	600	700	210	1
CR 4 24 F - Y	1 1/8	28.6	3/4	19.0	1"-14	5/8	15.8	900	360	580	600	180	1
CR 5 25 Q - Y	1 1/8	28.6	7/8	22.2	1"-14	5/8	15.8	900	360	580	600	180	2
CR 5 33 Q - Y	1 3/8	35.0	1 1/8	28.6	1 1/4"-12	7/8	22.2	1000	405	660	700	210	2
CR 7 33 Q - Y	1 3/8	35.0	1 1/8	28.6	1 1/4"-12	7/8	22.2	970	405	685	700	230	2
CR 7 39 S - Y	1 3/8	35.0	1 1/8	28.6	1 1/4"-12	3/4	19.0	1000	405	660	700	210	2
CR 10 39 S - Y	1 3/8	35.0	1 1/8	28.6	1 1/4"-12	7/8	22.2	970	405	685	700	230	2
CR 10 51 S - Y	1 3/8	35.0	1 1/8	28.6	1 1/4"-12	7/8	22.2	970	405	685	700	230	2
CR 15 51 S - Y	1 5/8	42.0	1 1/8	28.6	1 1/4"-12	7/8	22.2	970	405	685	700	230	2
CR 20 56 S - Y	1 5/8	42.0	1 1/8	28.6	1 1/4"-12	7/8	22.2	970	405	685	700	230	2
CR 15 71 V - Y	1 5/8	42.0	1 1/8	28.6	1 3/4"-12	1 1/8	28.6	970	465	792	700	260	3
CR 20 84 V - Y	1 5/8	42.0	1 1/8	28.6	1 3/4"-12	1 1/8	28.6	970	465	792	700	260	3
CR 30 84 V - Y	2 1/8	54.0	1 3/8	35.0	1 3/4"-12	1 1/8	28.6	1200	465	810	700	260	3
CR 25 106 Z - Y	2 1/8	54.0	1 3/8	35.0	1 3/4"-12	1 1/8	28.6	1200	512	747	700	260	4
CR 35 106 Z - Y	2 1/8	54.0	1 3/8	35.0	1 3/4"-12	1 1/8	28.6	1170	512	801	700	310	4
CR 30 126 Z - Y	2 1/8	54.0	1 3/8	35.0	1 3/4"-12	1 1/8	28.6	1200	512	823	700	260	4
CR 40 126 Z - Y	2 5/8	67.0	1 5/8	42.0	1 3/4"-12	1 1/8	28.6	1170	512	877	700	310	4
CR 40 154 Z - Y	2 5/8	67.0	1 5/8	42.0	1 3/4"-12	1 1/8	28.6	1200	512	823	700	260	4

① disegni da pagina 16 a 17
drawings from page 16 to 17
plans de page 16 à 17
Zeichnungen von Seite 16 bis 17

FTEC09-04

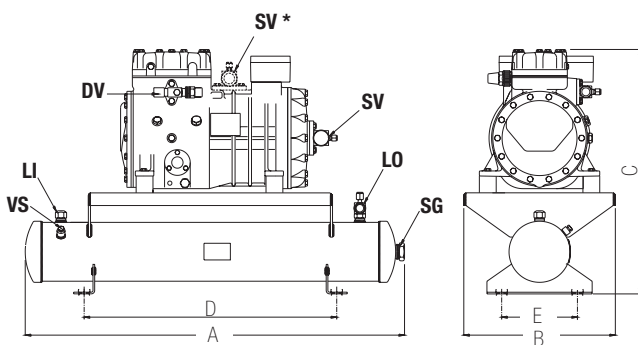

* posizione del rubinetto di aspirazione per il modello CR 4 24 F-Y
suction valve location for model CR 4 24 F-Y
position de la vanne d'aspiration pour le modèle CR 4 24 F-Y
Stellung des Saugventiles für das Modell CR 4 24 F-Y

Disegno Drawing
Plan Zeichnung **1**

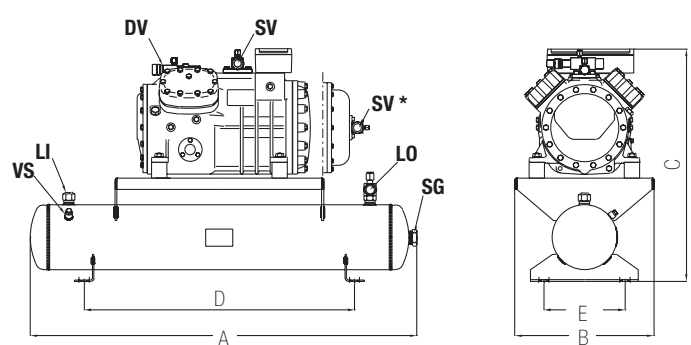

* posizione del rubinetto di aspirazione per i modelli:
suction valve location for models:
position de la vanne d'aspiration pour les modèles:
Stellung des Saugventiles für die Modelle:
CR 7 39 S-Y, CR 10 39 S-Y, CR 10 51 S-Y, CR 15 51 S-Y, CR 20 56 S-Y

Disegno Drawing
Plan Zeichnung **2**

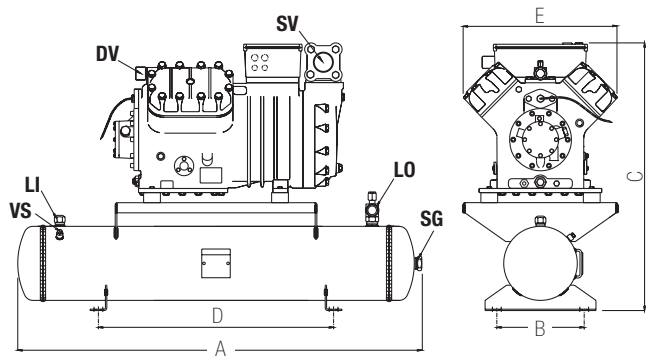

Disegno Drawing 3
Plan Zeichnung

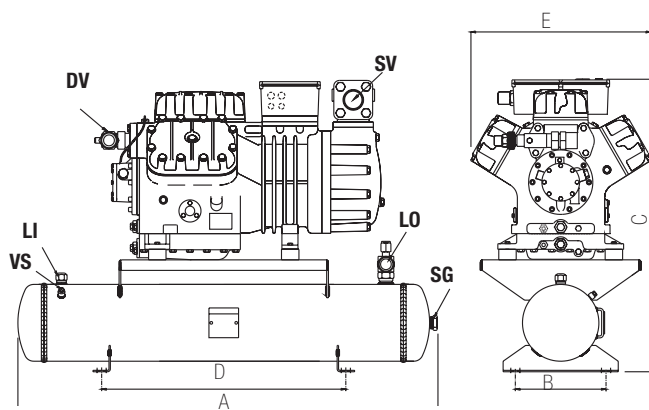

Disegno Drawing 4
Plan Zeichnung

Legenda

Legend

Légende

Legende

DV	rubinetto di compressione	discharge valve	vanne de refolement	Druckventil
LI	attacco ingresso liquido	inlet liquid connection	entrée du liquide	Kältemittel-Eintritt
LO	rubinetto uscita liquido	outlet liquid valve	sortie du liquide	Kältemittel-Austritt
SG	spia livello liquido	liquid sight glass	voyant de niveau	Schauglas
SV	rubinetto di aspirazione	suction valve	vanne d'aspiration	Saugventil
VS	tappo per valvola di sicurezza	safety valve plug	bouchon pour vanne de sûreté	Stopfen Sicherheitsventil

FTEC09-04

