

Dimensional drawing

Series **B**

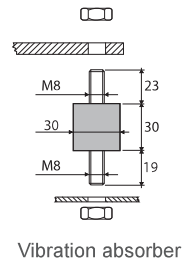
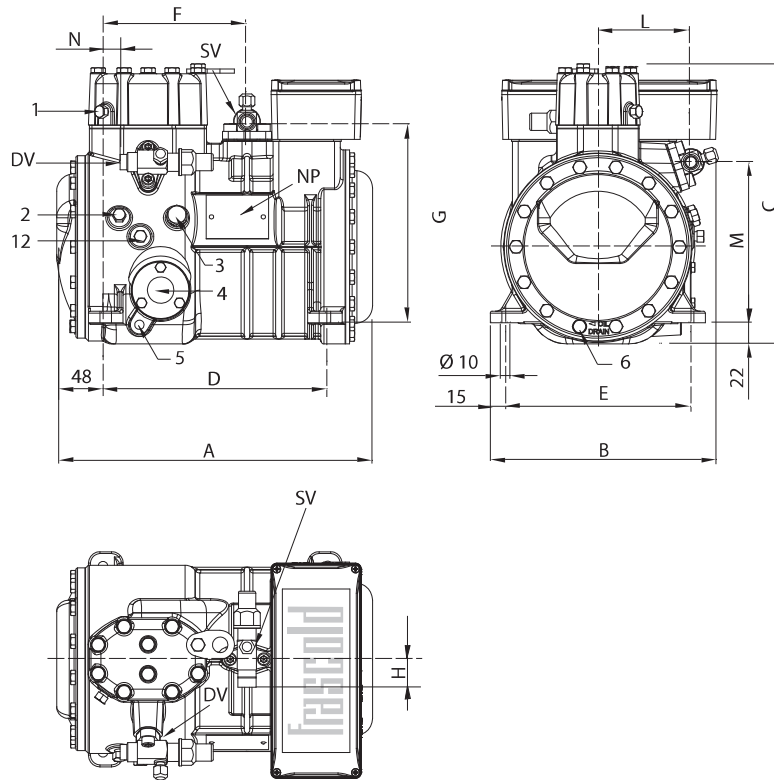

1	High pressure plug	1/8" NPT
2	Low pressure plug	1/8" NPT
3	Oil charge plug	1/4" GAS
4	Oil level sight glass	
5	Crankcase heater seat	
6	Oil drain plug	M8 x 22 ISO4017
12	Oil return plug	1/8" NPT
DV	Discharge valve	
SV	Suction valve	
NP	Nameplate	

Compressor	Valves				Valves position						Compressor				
	Suction		Discharge		Suction			Discharge			Length	Width	Height	Base mounting	
	Ø	Ø	Ø	Ø	F	G	H	L	M	N	A	B	C	D	E
	"	mm	"	mm	mm	mm	mm	mm	mm	mm	mm	mm	mm	mm	mm
B1.5-9.1Y	5/8	15,8	1/2	12,7	150	209	29	97	167	18	329	237	292	234	194
B1.5-10.1Y	5/8	15,8	1/2	12,7	150	209	29	97	167	18	329	237	292	234	194
B2-10.1Y	3/4	19,0	5/8	15,8	150	209	31	97	167	18	334	237	292	234	194